



Beginner-friendly appliqué
with *Bella Coco*



Cheerful
designs

SIZES
6-36

crochet now

THE UK'S NO.1 CROCHET MAGAZINE



BABY MAKES TO CHERISH

COLOURS MADE EASY

- ✓ Rainbow crochet ideas
- ✓ 4 bright blankets
- ✓ One-ball hat



OFFICIAL
Sooty
BLANKET



CUTE TOYS UNDER £10

33

PATTERNS
just for you!



MAKE ME TONIGHT!

INSIDE:

Win a year of yarn
20% off King Cole yarn
New from TOFT
& more!



ISSUE 77 UK £6.99



9 772397 414012



77>

www.craftworld.com

WEST YORKSHIRE SPINNERS

FLEECE

– 100% British Wool –

Bluefaced Leicester

DK

Discover our new colours and find
your local stockist at [wyspinners.com](https://www.wyspinners.com)



[wyspinners.com](https://www.wyspinners.com) • sales@wyspinners.com • 01535 664500

Issue 77

On Cloud 9

FREE
crochet
society
Coco Cushion CAL
when you subscribe
See page 29



It is officially 2022 – I hope you had a wonderful break and feel ready to **face the year head on!** Have you made any resolutions for the new year? I've decided to teach myself Korean, if I can find the time, as well as to **continue improving** my own crochet skills!

There's a **sense of calm** in the air after the wonderful madness of the Christmas period, and the feeling that brighter days are on the way. This issue is full of **comforting and cheerful designs** to give you that little bit of a boost as we eagerly await the spring. We have plenty of soft winter garments to **brighten your wardrobe**, such as the **delicate pastel Dulce Poncho** (page 74). There are plenty of quick makes to get started on tonight, including the Wild Berries Slouch Hat (page 10) that requires just one ball of yarn! If you're looking for something a **little slower paced and**

intricate, why not have a go at hooking up a beautiful **Boho Rainbow Blanket** (page 62) to brighten those January nights?

Looking to test your abilities and **try out some new stitches**? The Blooming Blossoms Wall Hanging (page 30) contains a **variety of stitches** to create this stunning floral piece for your home. **For the little ones** in your life, the Funky Donkey Blanket Hoodie (page 18) is ideal for keeping them snug. However, my personal favourite would have to be the incredible **Super Sooty Blanket** (page 14), that is a fun way of bringing a splash of colour into any home!

This month's **Crochet Rescue Kit** is the perfect addition to your collection, which is great for beginners and more experienced crocheters alike! Be sure to share your *Crochet Now* projects with us via email or online to show off your **newly learned techniques** for 2022!

Keep smiling!

Hannah

Editor
hannah.williams@practicalpublishing.co.uk

I hope you find your exclusive Crochet Rescue Kit useful!



For subscription enquiries please
call **0161 327 0441**
or email subscriptions@practicalpublishing.co.uk



crochetnowmag



@crochetnowmag



crochetnowmag



crochetnowmag



Crochet Now



10

INSIDE THIS ISSUE...



36

24

Projects



10 WILD BERRIES SLOUCH HAT

Hook up one of these snuggly hats with only one ball of yarn and stay cosy this winter!

12 DREAMY CLOUD MAKE-UP POUCH

Keep all your beauty supplies safe and sound in this beautiful make-up pouch

14 SUPER SOOTY BLANKET

Add a touch of magic to your home by hooking up this amazing Sooty blanket!

18 FUNKY DONKEY BLANKET HOODIE

Keep your little animals snug this winter by hooking up this fun blanket hoodie

24 PUFFY THE CLOUD

Bring this adorable ball of fun into your home tonight!

30 BLOOMING BLOSSOMS WALL HANGING

Learn multiple new stitches by hooking up this beautiful wall hanging using colourful yarn

36 UP IN THE CLOUDS JUMPER

Slip into spring with this beautifully delicate cropped jumper that's equally comfortable and stylish

40 TWILIGHT TONES BLANKET

Slip into sweet dreams under this beautiful two-toned blanket

42 COMFY CHIC WRAP

Keep yourself warm and spruce up your 2022 wardrobe with this beautiful wrap

52 WEATHERMAN JUMPER

Hook up one of these adorable jumpers for your little ray of sunshine!

56 SPRING SHOWERS COWL

Be prepared for whatever the spring has in store by wrapping up warm in this gorgeous cowl

62 BOHO RAINBOW BLANKET

Add a splash of joy into your home with this beautiful Boho Rainbow Blanket

64 IMOGEN THE ICE SKATER

Imogen loves to skate with her friends and have hot chocolate and marshmallows by the fire!

72 BOBBLE CLOUD CUSHION

This colourful cloud cushion incorporates bobbles that look like raindrops

74 DULCE PONCHO

Face the winter head on with this stunning poncho, made from a mix of yarns

77 POPCORN SCARF

We're so excited to 'pop' this super cosy scarf in this month's issue

NEED SOME HELP? Our patterns go through several checks for accuracy, but sometimes errors do slip through the gaps. Before contacting the Editor, head to www.crochetnow.co.uk/category/errata to see if there's already a fix – if not, let us know by email at contact@crochetnow.co.uk



18



82

30



82 MAKE WITH THE STYLECRAFT EXPERT
Hook up this colourful blanket that's perfect for keeping you warm this winter!

Regulars

6 WHAT'S NEW

The woolly things that are not to be missed and are making our month

9 READERS' MAKES

Show us your *Crochet Now* makes for a chance to win a yarny prize from Cygnet

28 SAVE & WIN!

Save 20% on King Cole yarn, plus enter today for your chance to win a year's supply of yarn from Wool Warehouse!

22 BELLA COCO CROCHET CHRONICLES

Sarah-Jayne shares her excitement for spring and a lovely bunny appliqué pattern

32 ENIGMA CAL PART 10

An exclusive design from Esther Dijkstra, we continue with Part 10 of the *Crochet Now* CAL

39 SCHEEPJES TOP PICKS

Matt Farci guides us through his picks of Scheepjes's new products

44 DESIGNER INTERVIEW

Janine Myskas talk about *Modern Crochet Sweaters* and shares a brilliant pattern from the book!

49 KERRY'S JOURNAL

Kerry shares what TOFT's doing to celebrate inspirational women around the world

59 YOUR CROCHET COMMUNITY

We've teamed up with Wallace & Gromit and UK Handknitting to promote local yarn shops and share what's new in your community

67 THE BOOK CLUB

This month, we're diving into *Modern Crochet Style*, the brilliant new book from Lindsey Newns!

79 ABBREVIATIONS

Learn your dc from your BLO with *Crochet Now's* abbreviation guide

80 COMING SOON

As we start to think about spring, take a moment to breathe slowly as you work through this beautiful collection of mindful crochet makes in the next issue of *Crochet Now!*

WHAT'S NEW?

These are the yarns, patterns, books and tidbits of woolly wonder that will make your month

Is your yarn worthy?

The talented Emma of Yarnworthy is releasing some gorgeous new skeins of yarn perfect for your wintry makes. Yarnworthy stocks many stunning hand-dyed yarns, including 100% fine organic Merino non-superwash, 100% British Blue Face Leicester and a truly luxurious Silky Yak yarn dyed in stunning shades. You can also have these beautiful yarns dyed to order, so be sure to check out this exciting shop update.

www.yarnworthy.co.uk



20% OFF KING COLE!

Want to stock up on all your favourite King Cole yarns? You can get 20% off King Cole yarns at Wool Warehouse! Using the code **CN77KC**, get your hook into gorgeous King Cole yarns (excluding KC Naturally Soft 4-ply); King Cole produces a huge range of yarns, perfect for any project. Browse yarns such as Big Value, Drifter and Cottonsoft in every shade available at Wool Warehouse.

www.woolwarehouse.co.uk



Don't forget to follow us at **CROCHETNOWMAG**.

FOLLOW YOUR PASSION!

Instagram is full of inspirational crocheters and influencers, and these are the three to follow this month!

www.instagram.com



thenewmoondesigns

With beautiful shawls, warm makes and a lovely rustic feel, we love the **thenewmoondesigns** Instagram on wintry mornings and for when we need some cosy inspiration.

redsparrowcrochet

We love a beautiful mosaic crochet pattern, so this Instagram account is perfect for whiling away the hours admiring these stunning patterns.



yarngonewild_yarncraftt

If funky hats are your thing, then you will absolutely love **yarngonewild_yarncraftt**. Designer Tanya shares gorgeous hats she's created with a unique and exciting style.

**BOOK
review**

**Modern
Crochet
Sweaters**

By Janine Myska
£17.99

Page Street Publishing

Modern Crochet Sweaters: 20 Chic Designs for Everyday Wear is the fabulous new book by the wonderful designer Janine Myska, the talent behind Knit 'n Knots. Create the crochet wardrobe of your dreams with these 20 gorgeous sweater patterns that focus on style, fit and comfort. Included in the book are brilliant customisation tips and ideas. Each pattern comes in size XS-5XL, so the book is wonderfully size-inclusive and is ideal for every skill level from beginner to expert. *Modern Crochet Sweaters* features the Mountain Peaks striped cardigan and the Fifty Below Color Block Pullover. There are sweater styles for everyone and the perfect sweater for every occasion, whether you are on your way to a fancy dinner party or taking the kids to the park!

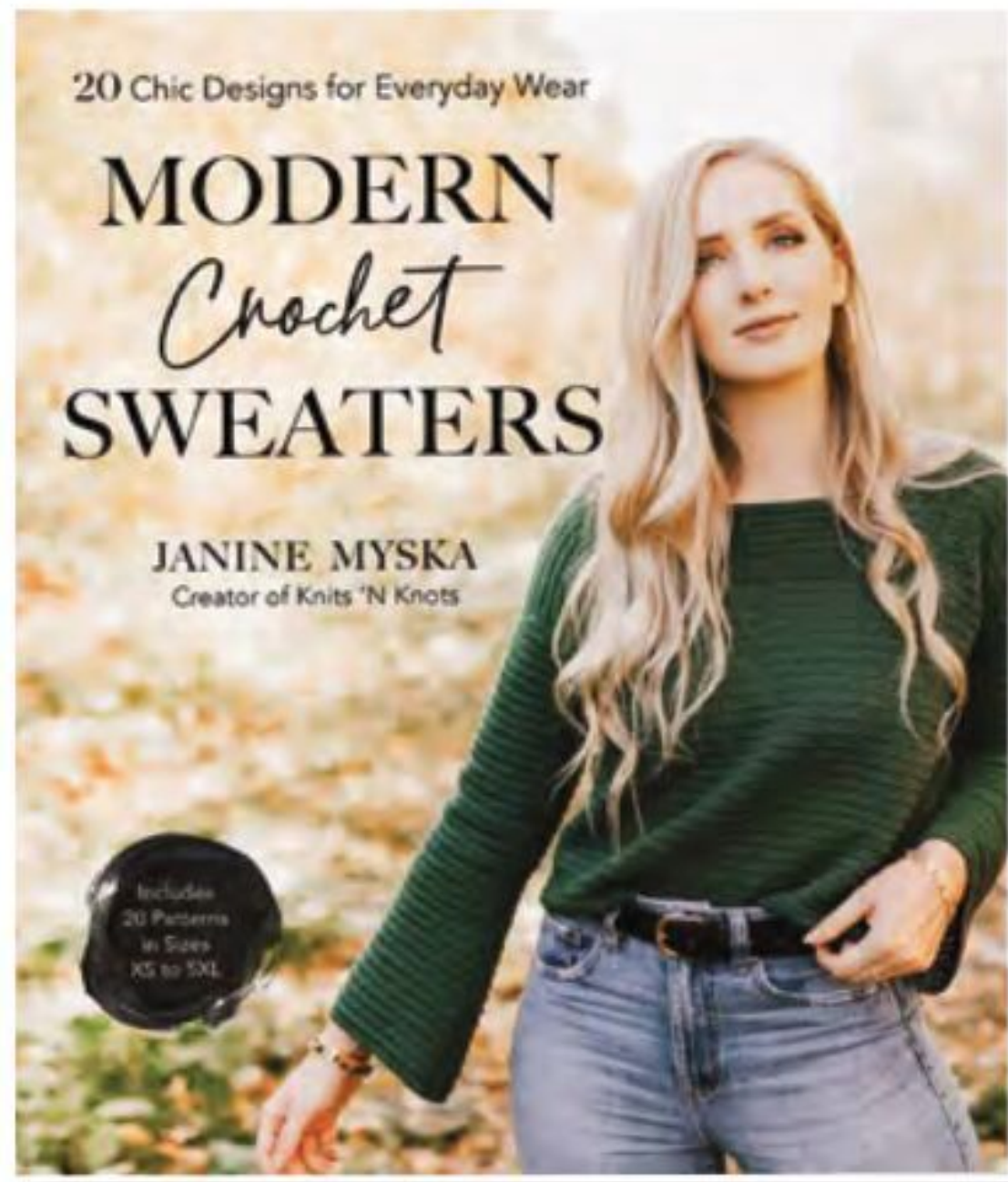

PREMIUM PATTERNS!

You can now get a whole range of fabulous crochet patterns on CraftWorld! These incredible patterns are available when you join as a CraftWorld premium member, so you can download at your leisure and crochet these beautiful designs by some of the biggest designers in the craft world. These digital patterns are ideal for zooming into lace charts or highlighting different sections of these beautiful designs. Don't miss picking up these fabulous patterns every month to add to your project stash.

Go to www.craftworld.com/cms/premium to get your premium membership today.



Super sweater

How cool is this sweater from Scheepjes? The Misha Sweater is the latest crochet pattern from the stylish designers at Scheepjes, and we can't wait to make one! This playful sweater is crocheted in Scheepjes Secret Garden yarn and would look perfect worn casually with jeans or dressed up with a fancy skirt. This sweater features a boat neckline, ribbed detailing to the hem, cuffs and full length and is a fun and eye-catching piece.

www.scheepjes.com

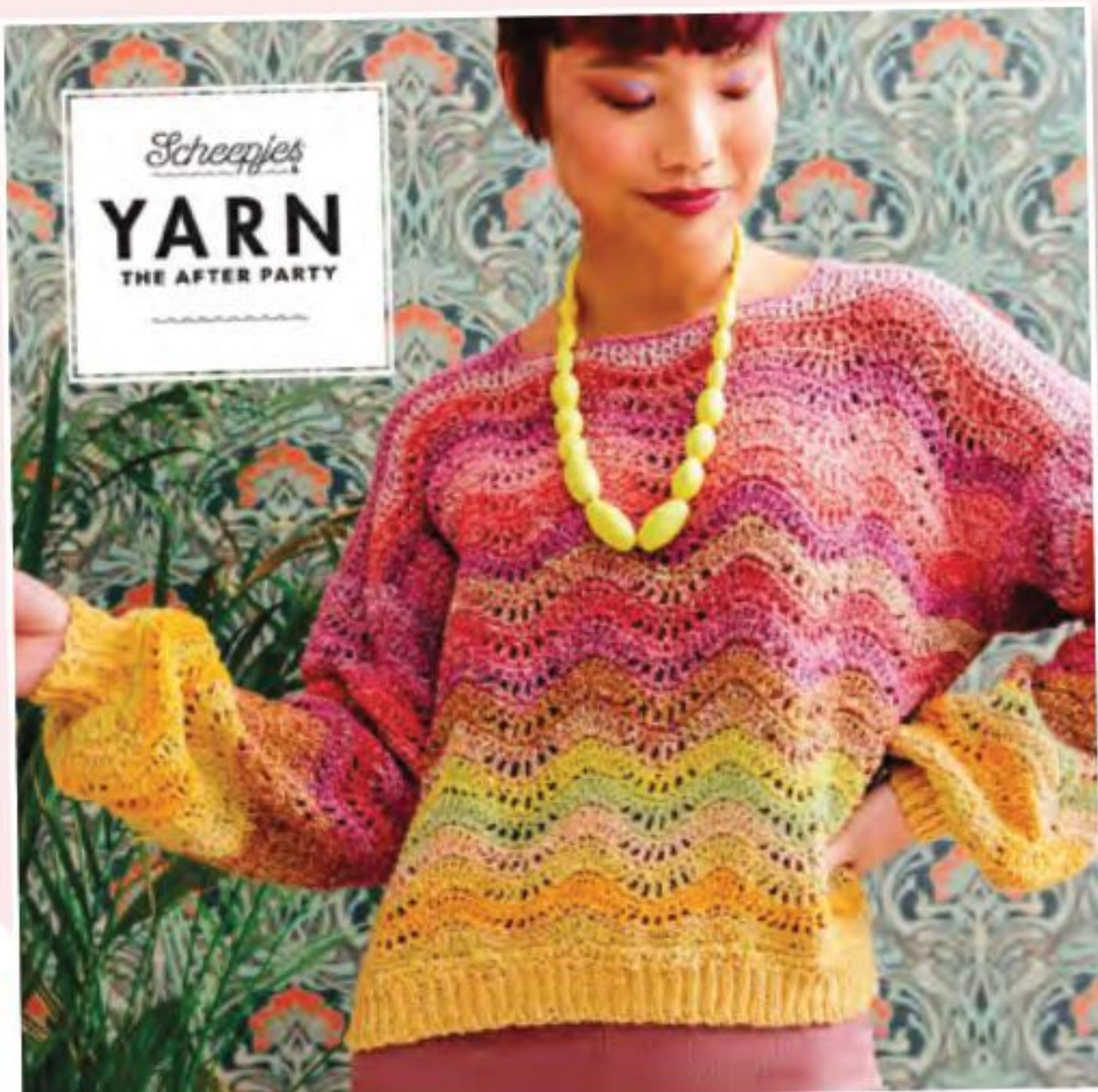





Stylecraft

life dk

75% acrylic, 25% wool

now in
43
shades



For your nearest stockist telephone 01484 848435 Stay up-to-date   www.stylecraft-yarns.co.uk

SHOW US YOUR MAKES

Send in a photo of your Crochet Now project and, if you're featured, you will win three balls of Cygnet yarn!

.....



Shay Shaw,
Pretty Poinsettia Gnome, issue 73

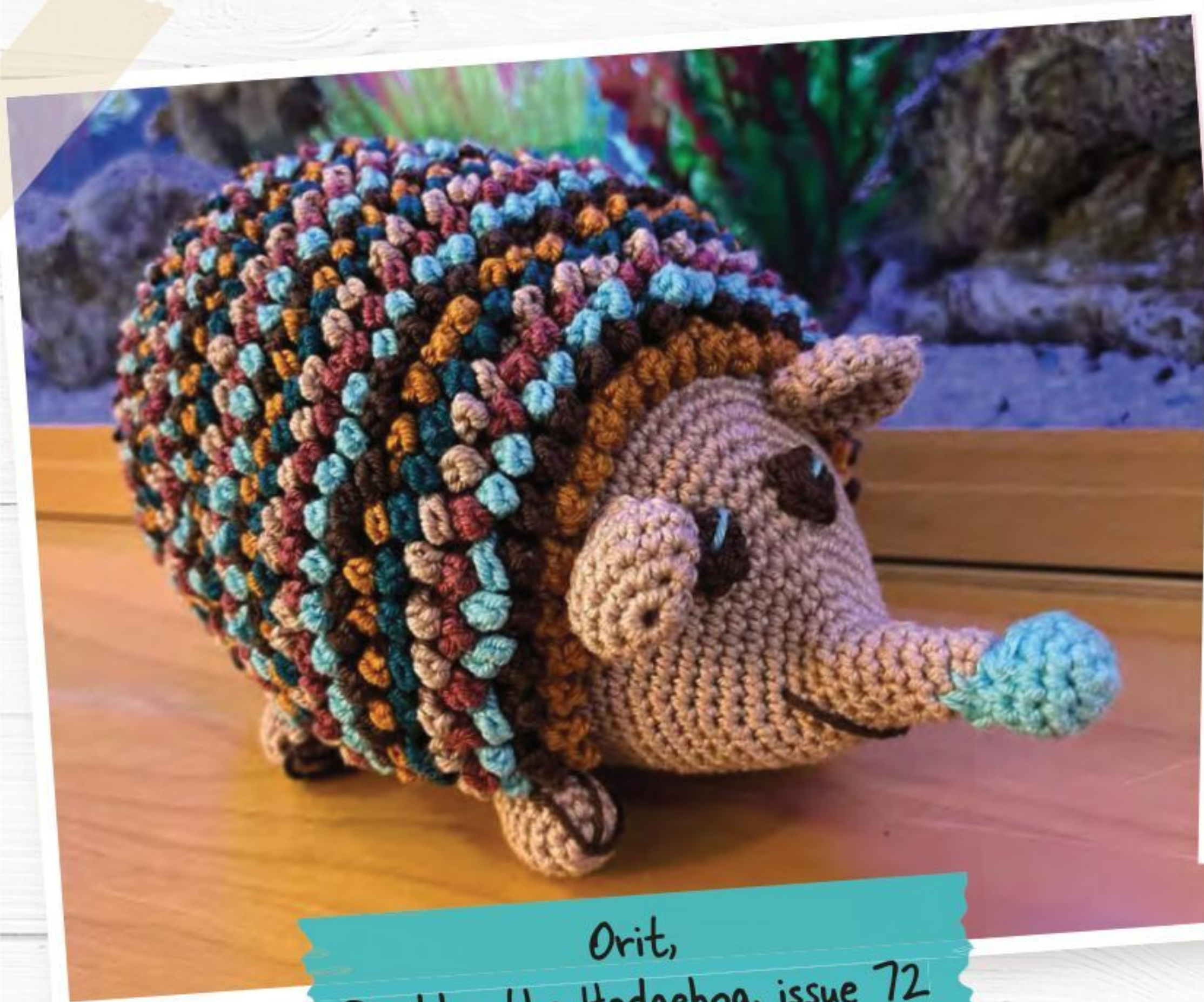

Orit,
Prickles the Hedgehog, issue 72

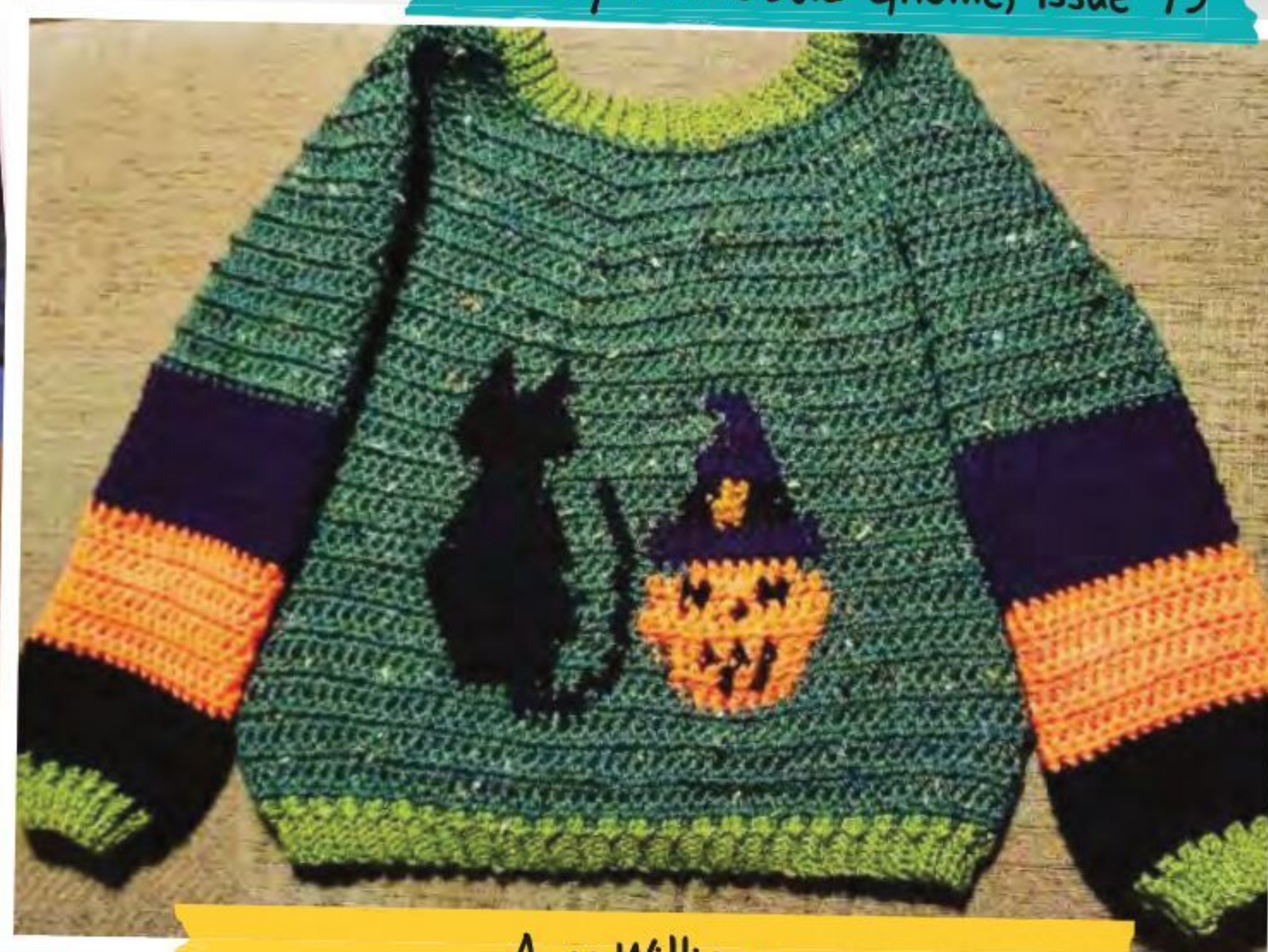

Amy Williams,
Salem's Spell Children's Jumper, issue 73



Alice Cowie,
Pusheen, issue 74

Tag us with your *Crochet Now* makes on Facebook, Instagram or Twitter, or send them by email to **contact@crochetnow.co.uk** for your chance to be featured here



Jayde McNamee,
Granny Square Skirt, issue 70

IN ASSOCIATION WITH



WWW.CYGNETYARNS.COM



WILD BERRIES SLOUCH HAT

Hook up one of these snuggly hats
with only one ball of yarn and
stay cosy this winter!

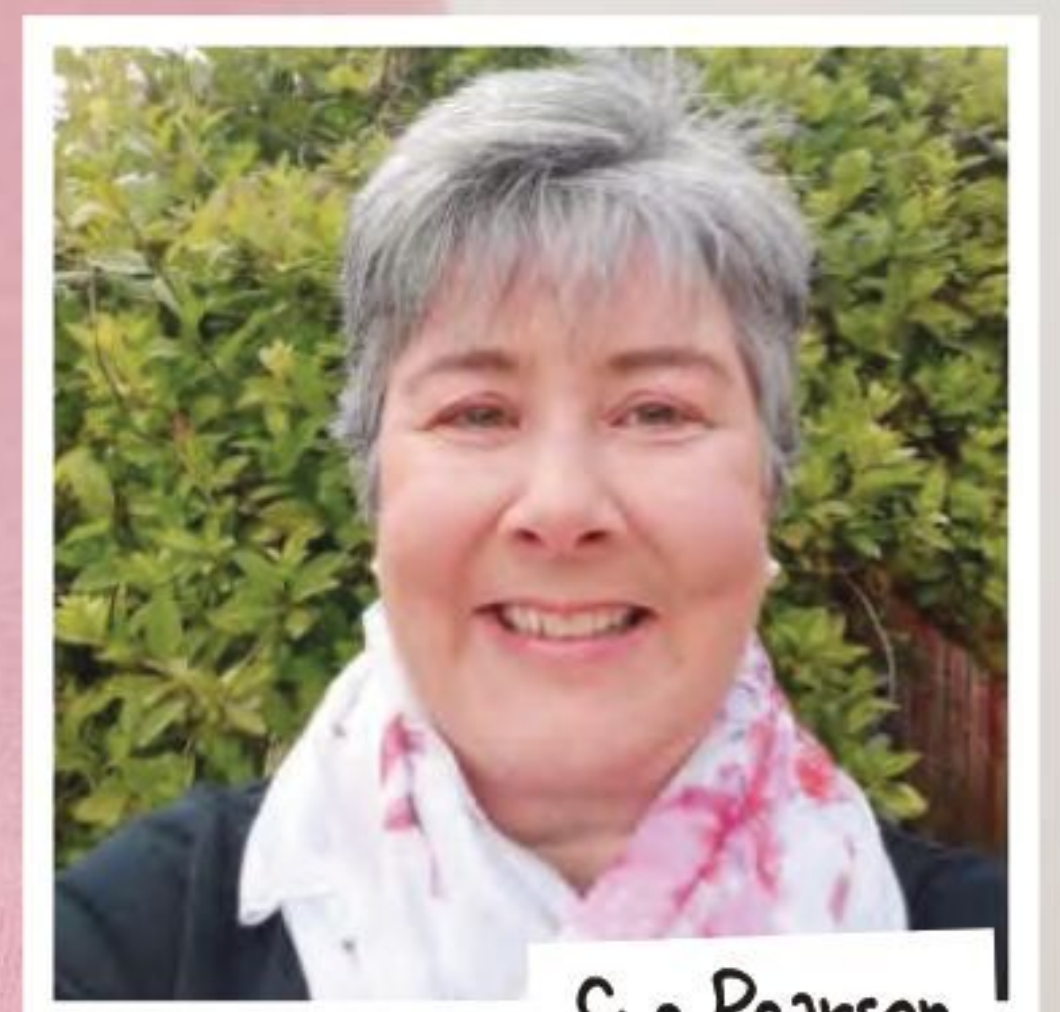

Sue Pearson

 DK  4.5 & 5mm

★★ Intermediate

Yarn used

King Cole Harvest
1 ball in Babbling Brook 5207
Visit www.kingcole.com to find your
local stockist

About the yarn

DK; 535m per 150g ball; 90% acrylic,
10% alpaca

Tension

15 sts x 8 rows = 10cm measured over tr
with larger hook

Hooks used

4.5mm
5mm

Other supplies

stitch markers

Sizing

48cm circumference
.....

When instructed to turn at the end of a round, mark the last st worked with a marker so that when you turn, the first st of the round is easy to find.

When working the round following a 'bobble rnd', it's easier to find the closing st if you rotate the bobble towards you slightly.

Beg ch does not count as a st unless otherwise specified.

Start crocheting...

Hat is worked top down in rnds, do not turn at the end of the rnd unless specified.

- Rnd 1:** With larger hook and working into a magic ring, 3 ch (counts as first tr), 23 tr, join with sl st in top of beg 3 ch, pm in 2nd tr for st placement in Rnd 3. *24 tr*
- Rnd 2:** 1 ch, 1 dc, 3 ch, miss next st, *1 dc, 3 ch, miss next st; rep from * around, join with sl st to beg dc. *12 dc*
- Rnd 3:** [1 sl st, 1 ch, 1 dc] into first 3ch-sp, 1 RpcF around marked st in Rnd 1, 1 dc into same first 3ch-sp, *1 dc into next



- 3ch-sp, miss next tr in Rnd 1, 1 RpcF around next tr in Rnd 1, 1 dc into same 3ch-sp as previous dc; rep from * around, join with sl st to beg dc. *24 dc, 12 RpcF*
- Rnd 4:** 1 ch, 2 dc in first dc, *miss next RpcF, [2 dc in next dc] twice; rep from * around to last RpcF, miss last RpcF, 2 dc in last dc, join with sl st to beg dc. *48 dc*
- Rnd 5:** 1 ch, 2 htr in first st, 1 htr, *2 htr in next st, 1 htr; rep from * around, join with sl st to beg htr. *72 htr*
- Rnd 6:** 1 ch, 2 htr in BLO of first st, 2 htr in BLO, *2 htr in BLO of next st, 2 htr in BLO; rep from * around, join with sl st to beg htr. *96 htr*
- Rnd 7:** 3 ch (counts as first RtrB), 22 RtrB, 2 RtrB around next st, *23 RtrB, 2 RtrB around next st; rep from * around, join with sl st in top of beg 3ch. Turn. *100 RtrB*
- Rnd 8 (WS):** 1 ch, *1 bbl, 4 dc; rep from * around, join with sl st to beg bbl. Turn. *20 bbl, 80 dc*
- Rnd 9 (RS):** 1 ch, htr around, join with sl st to beg htr. Turn.
- Rnd 10 (WS):** 1 ch, 3 dc, 1 bbl, *4 dc, 1 bbl; rep from * to last st, 1 dc, join with sl st to beg dc. Turn. *20 bbl, 80 dc*
- Rnd 11 (RS):** 3 ch (counts as first tr), tr around, join with sl st in top of beg 3 ch.
- Rnd 12:** 3 ch (counts as first tr), 1 RtrtrF/RdtrFtog over bbl on Rnd 8 and next bbl on Rnd 10, *miss next st on Rnd 11, 4 tr, 1 RtrtrF/RdtrFtog over next 2 bbls on rnds 8 and 10; rep from * to last 4 sts, miss next st on Rnd 11, 3 tr, join with sl st in top of beg 3 ch. *20 RtrtrF/RdtrFtog, 80 tr*
- Rnd 13:** 3 ch (counts as first RtrB), *1 RtrB around next st; rep from * around, join with sl st in top of beg 3 ch. *100 RtrB*
- Rnd 14:** 1 ch, htr around, join with sl st to beg htr.
- Rnd 15:** As Rnd 13. Turn.
- Rnds 16-19:** Rep rnds 8-11.
- Rnd 20:** 3 ch (counts as first tr), 1 RtrtrF/RdtrFtog over bbl on Rnd 16 and next bbl

on Rnd 18, *miss next st on Rnd 19, 4 tr, 1 RtrtrF/RdtrFtog over next 2 bbls in rnds 16 and 18; rep from * to last 4 sts, miss next st on Rnd 19, 3 tr, join with sl st in top of beg 3 ch. *20 RtrtrF/RdtrFtog, 80 tr*

Rnds 21-22: Rep rnds 13-14.

Rnd 23: As Rnd 13.

Rnd 24 (WS): 1 ch, *1 bbl, 4 dc; rep from * around, join with sl st to beg bbl. Turn. *20 bbl, 80 dc*

Rnd 25 (RS): As Rnd 14.

Rnds 26-27: Rep rnds 13-14.

Rnd 28 (beg Band): 1 ch, *1 dc2tog, 8 dc; rep from * around, join with sl st to beg dc. *90 dc*

Rnd 29: 1 ch, dc around, join with sl st to beg dc.

Change to smaller hook.

Rnd 30: 1 ch, *1 dc, 1 ch, miss next st; rep from * around, join with sl st to beg dc.

Rnd 31: [1 sl st, 1 ch, 1 dc] into first 1ch-sp, 1 ch, miss next st, *1 dc into next 1ch-sp, 1 ch, miss next st; rep from * around, join with sl st to beg dc.

Rnds 32-34: As Rnd 31.

Rnd 35: 1 ch, 1 dc in first st, 1 dc into next 1ch-sp, *1 dc, 1 dc into next 1ch-sp; rep from * around, join with sl st to beg dc. *90 dc*

Rnds 36-40: 1 ch, dc around, join with sl st to beg dc.

Fasten off. Weave in ends. 

Special stitches

RhtrB – Raised half treble Back:

Work the htr around post of indicated st, inserting hook from back to front around to back again

RpcF – Raised popcorn Front: Work 4 tr around the post of indicated st, inserting hook from front to back around to the front again, after completing 4th tr, drop loop from hook, insert hook from front to back in first of 4 tr, place loop back on hook, draw through first st

Bobble (bbl): [Yrh, insert hook into st, yrh, pul, yrh, draw through 2 loops] 5 times into same st, yrh, draw through all 6 loops on hook

Raised triple treble Front/Raised double treble Front together

(RtrtrF/RdtrFtog): Work trtr around post of lower specified bbl, inserting hook from front to back around to front again and leaving last 2 loops on hook, work dtr around post of next (higher) bbl in the same manner, leaving last 2 loops on hook (for 3 loops on hook total), yrh, draw through all 3 loops on hook

DREAMY CLOUD MAKE-UP POUCH

Keep your spirits sky high by storing all your beauty supplies safe and sound in this beautiful make-up pouch



Special abbreviations

Invisible join: Cut yarn, leaving a long tail, thread tail onto tapestry needle, insert needle in 2nd st of rnd under both top loops, insert needle in BLO of last st of rnd, tug gently until join matches tension of underlying sts. Weave in end securely on WS



Zoë Potrac

DK 4mm

★ Beginner friendly

Yarn used

Sirdar Happy Cotton
2 balls in Dolly 761 (MC)
1 ball each in Piggy 764 (CC1), Sorbet 793 (CC2), Sundae 787 (CC3), Squeaky 783 (CC4), Bubbly 785 (CC5), Unicorn 769 (CC6) & Liquorice 775 (CC7)
Visit www.sirdar.com to find your local stockist

About the yarn

DK; 43m per 20g ball; 100% cotton

Tension

18 sts x 22 rows = 10cm

Hook used

4mm

Other supplies

tapestry needle
35cm zip (or choose one that can be cut to length when complete)
sewing needle
sewing thread to match zip

Sizing

23cm wide x 12cm tall x 5cm deep

Take your time with the sl st edges and joining to give the neatest finish.

Start crocheting...

Cloud Shape (make 2)

With MC, chain 11.

Row 1: Starting in 2nd ch from hook, 10 dc. Turn. 10 sts

Row 2: 1 ch, 9 dc, 2 dc in last st. Turn. 11 sts

Row 3: 1 ch, 2 dc in first st, 10 dc. Turn. 12 sts

Row 4: 1 ch, 11 dc, 2 dc in last st. Turn. 13 sts

Rows 5-7: 1 ch, 13 dc. Turn.

Row 8: 1 ch, 11 dc, 1 dc2tog. Turn. 12 sts

Row 9: 1 ch, 1 dc2tog, 10 dc. Turn. 11 sts

Row 10: 1 ch, 9 dc, 1 dc2tog. Turn. 10 sts

Row 11: 6 ch, starting in 2nd ch from hook, 5 dc, cont across row, 10 dc. Turn. 15 sts

Row 12: 1 ch, 14 dc, 2 dc in last st. Turn. 16 sts

Row 13: 1 ch, 2 dc in first st, 15 dc. Turn. 17 sts

Row 14: 1 ch, 16 dc, 2 dc in last st. Turn. 18 sts

Rows 15-17: 1 ch, 18 dc. Turn.

Row 18: 1 ch, 16 dc, 1 dc2tog. Turn. 17 sts

Row 19: 1 ch, 1 dc2tog, 15 dc. Turn. 16 sts

Row 20: 1 ch, 14 dc, 1 dc2tog. Turn. 15 sts

Row 21: 6 ch, starting in 2nd ch from hook, 5 dc, cont across row, 15 dc. Turn. 20 sts

Row 22: 1 ch, 19 dc, 2 dc in last st. Turn. 21 sts

Row 23: 1 ch, 2 dc in first st, 20 dc. Turn. 22 sts

Row 24: 1 ch, 21 dc, 2 dc in last st. Turn. 23 sts

Rows 25-27: 1 ch, 23 dc. Turn.

Row 28: 1 ch, 21 dc, 1 dc2tog. Turn. 22 sts

Row 29: 1 ch, 1 dc2tog, 20 dc. Turn. 21 sts

Row 30: 1 ch, 19 dc, 1 dc2tog. Turn. 20 sts

Row 31: 1 ch, 5 sl st, 1 ch, 15 dc. Turn.

Rows 32-40: Rep rows 12-20. 15 sts

Row 41: 1 ch, 5 sl st, 1 ch, 10 dc. Turn.

Rows 42-50: Rep rows 2-10. 10 sts

Border Rnd: Sl st evenly around edge of Cloud (1 sl st in each st and each row end), join with sl st in beg sl st, when making 2nd piece, do not turn at end of Row 50. Fasten off.

Rainbow Stripe Edge

With CC1, chain 11.

Row 1: Starting in 2nd ch from hook, 10 dc. Turn. 10 sts

Row 2: 1 ch, 10 dc. Turn.

Rows 3-4: With CC2, as Row 2.

Rows 5-6: With CC3, as Row 2.

Rows 7-8: With CC4, as Row 2.

Rows 9-10: With CC5, as Row 2.

Rows 11-12: With CC6, as Row 2.

Rows 13-72: Rep the colour pattern as set, 1 ch, 10 dc.

Row 73: With CC1, 1 ch, 5 dc, leave rem sts unworked. Turn.

Rows 74-144: Cont in colour pattern, over these 5 sts.

Fasten off, join CC1 in next unworked st on Row 73 and rep rows 74-144 on the unworked side.

Fasten off. Weave in ends.

With CC1, sl st evenly around the edge of entire Rainbow Stripe.

Cheeks

Rnd 1: With CC1 and working into a magic ring, 6 dc, join with an invisible join.

Fasten off, leaving a long tail for sewing.



Making up

Using photograph as a guide for positioning, use tail to sew Cheeks onto one of the cloud pieces.

With CC7 and a tapestry needle, back stitch to embroider the eyes and mouth.

With a sewing needle and thread, sew the zip onto the Rainbow Stripe edge piece on each side of the long centre split.

With CC1, join the Rainbow Stripe edge piece to the front Cloud piece by slip stitching in BLO of the sl st edging on both the Cloud and the Rainbow Stripe. Rep for the back Cloud piece. With CC1, sew the ends of the Rainbow Stripe tog.

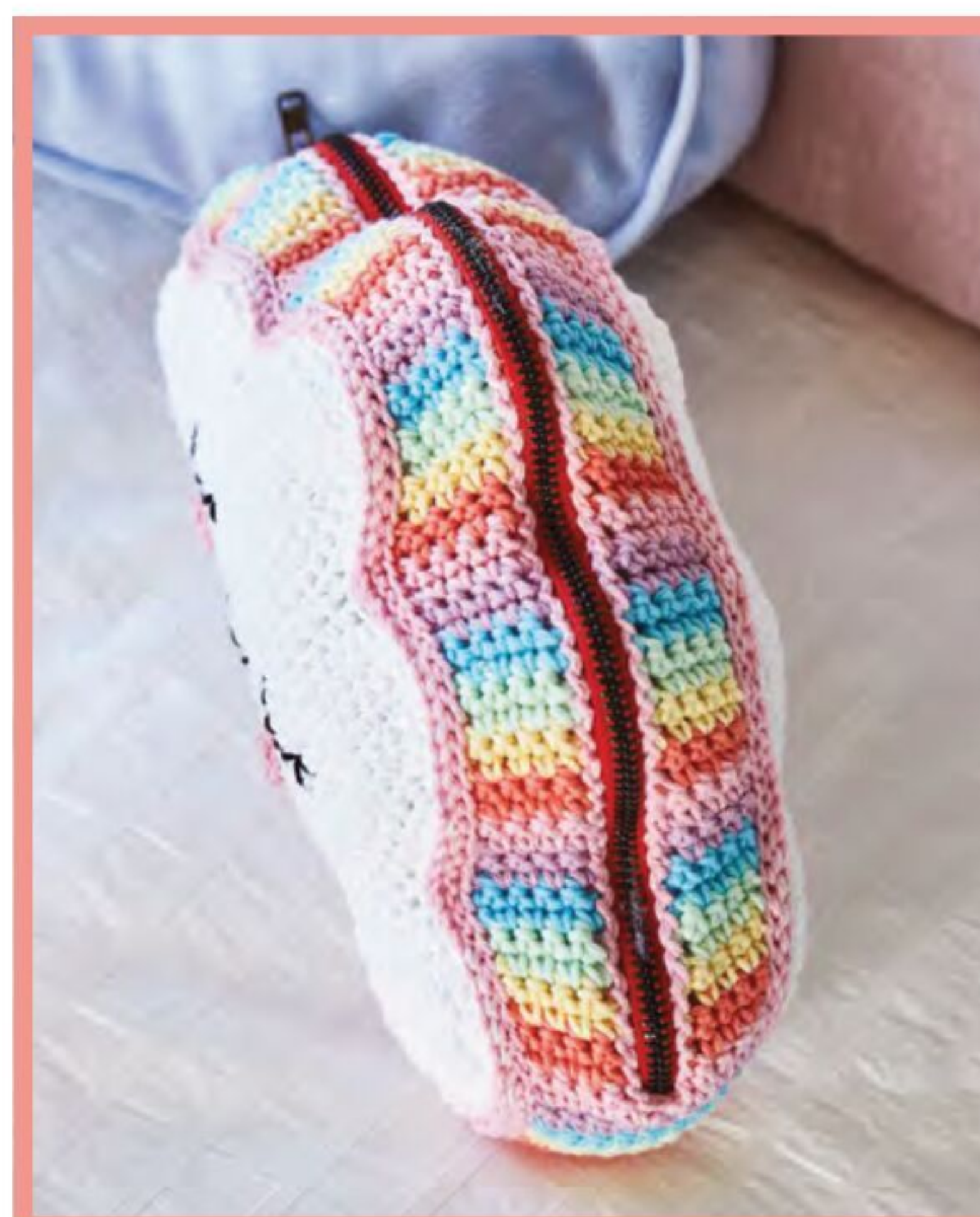

Super Sooty™ Blanket



Add a touch of magic to your home by hooking up this amazing corner-to-corner Sooty blanket!



Zoë Potrac

DK 4mm

★ Beginner friendly

Yarn used

Stylecraft Special DK
 3 balls in Cornish Blue 1841 (A)
 2 balls in Dandelion 1856 (C)
 1 ball each in black 1002 (B),
 white 1001 (D) & Walnut 1054 (E)
 Available from
www.woolwarehouse.co.uk

About the yarn

DK; 295m per 100g ball; 100% acrylic

Tension

7 blocks x 7 blocks = 10cm

Hook used

4mm

Sizing

Finished blanket measures 105x75cm
 including border



Start crocheting...

Where the colour changes to another and then changes back again within a short space, it is possible to carry the yarn across the back of the piece rather than cutting it and joining it again, reducing the number of ends to be sewn in at the end. If you do this, make sure to carefully crochet over the floats ensuring that they lay on the wrong side of the work. Don't do it over large expanses as the carried yarn may become visible on the front of the piece, spoiling the look of it.

Work stitches as below, following the chart on page 20 for colour changes.

Increase rows

With A, chain 6.

Row 1 (RS): Starting in 4th ch from hook, 3 tr. Turn. *1 block (3 ch, 3 tr)*

Row 2 (WS): 6 ch, starting in 4th ch from hook, 3 tr, [1 sl st, 3 ch, 3 tr] into 3 ch-sp of next block. Turn. *2 blocks*

Row 3: 6 ch, starting in 4th ch from hook, 3 tr, *[1 sl st, 3 ch, 3 tr] into 3ch-sp of next block; rep from * to end. Turn.

Rows 4-50: Cont increasing as for Row 3, following Chart for Colour changes (colour changes beg on Row 15). *50 blocks*

Maintain rows

Row 51: 6 ch, starting in 4th ch from hook, 3 tr, *[1 sl st, 3 ch, 3 tr] into 3ch-sp of next block; rep from * to last 3ch-sp, sl st into last 3ch-sp. Turn. *50 blocks*

Row 52: Sl st across to first 3ch-sp, [1 sl st, 3 ch, 3 tr] into first 3ch-sp, *[1 sl st, 3 ch, 3 tr] into next 3ch-sp; rep from * across. Turn. *50 blocks*

Rows 53-70: Rep rows 51-52.

Decrease rows

Rows 71-118: Sl st across to first 3ch-sp, [1 sl st, 3 ch, 3 tr] into first 3 ch-sp, *[1 sl st, 3 ch, 3 tr] into next 3ch-sp; rep from * to last 3ch-sp, sl st into last 3ch-sp. Turn. *1 block dec'd*

Row 119: Sl st across to 3ch-sp, [1 sl st, 3 ch, 3 tr] into 3ch-sp, sl st into next 3ch-sp. Do not turn. *1 block*

Border

Rnd 1: With RS facing, cont with A, 1 ch, 1 dc in sp between last block made and block with last sl st, 2 ch, {*1 dc in next sp between blocks, 2 ch; rep from * to next corner st, [1 dc, 2 ch, 1 dc] in corner st, 2 ch} 4 times, changing to D, join with sl st to beg dc. Fasten off A.

Rnd 2: With D, 3 ch, 2 tr into first 2ch-sp, *3 tr into each 2ch-sp across to corner 2ch-sp, 5 tr into corner 2ch-sp; rep from * around to last 2ch-sp, 3 tr into each rem 2ch-sp, join with sl st in top of beg 3 ch.

Rnd 3: Sl st in next 2 tr, 1 ch, {*1 dc in next sp between 3tr-groups, 2 ch; rep from * to next corner 3tr-group, [1 dc, 2 ch, 1 dc] in centre tr of corner 3tr-group, 2 ch} 4 times, [1 dc in next sp between 3tr-groups, 2 ch] twice, join with sl st to beg dc.

Rnd 4: As Rnd 2. Fasten off. Weave in ends.



Chart

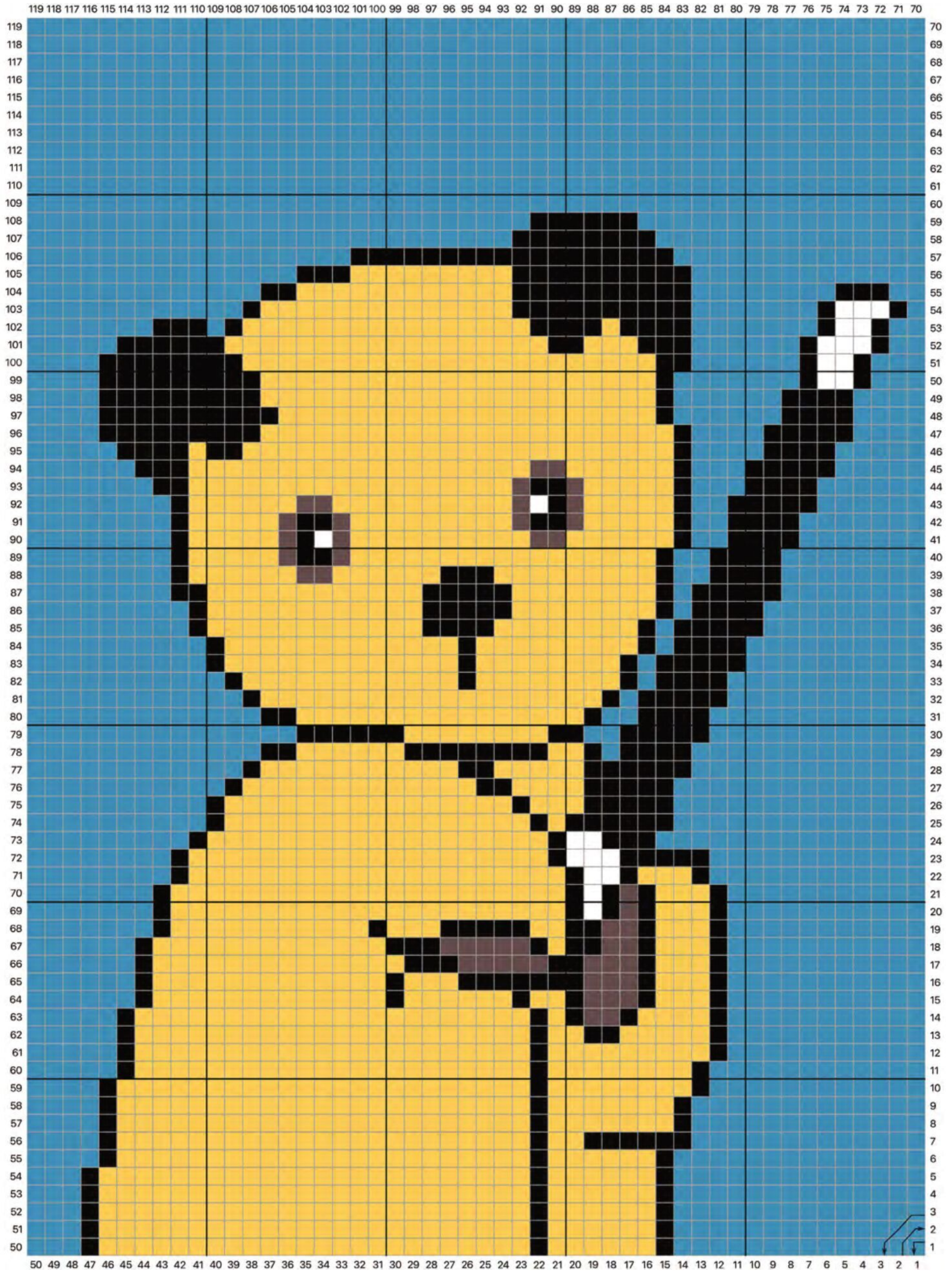

Key A B C D E ↙ direction of work



Big Value
dk 50g



RAINBOW BABY BLANKETS AND TOY

PATTERN 5502

Available from all good yarn retailers



kingcole.com

01756 703 670

enquiries@kingcole.com



FUNKY DONKEY BLANKET HOODIE

Keep your little animals
snug this winter by hooking
up this fun blanket hoodie

Designed by *Bernat Design Team*



Chunky **6.5mm**

★ **Beginner friendly**

Yarn used

Bernat Velvet
3 (4) balls in Smokey Green 32025 (MC)
1 (1) ball in white 32029 (CC)

About the yarn

Chunky; 288m per 300g ball; 100% polyester

Tension

10 sts x 11 rows = 10cm measured over dc

Hook used

6.5mm

Other supplies

stitch markers

Sizing

6/8 (10/12) years
to fit chest measurement: 63.5-67.5 (71-76) cm
finished chest measurement: 122 (147.5) cm

Body and Sleeves are crocheted in rnds until armhole.

At end of each rnd, turn work, to alternate rnds on RS and WS. This will ensure the sections worked in rnds will match sections worked in rows.

Schematic

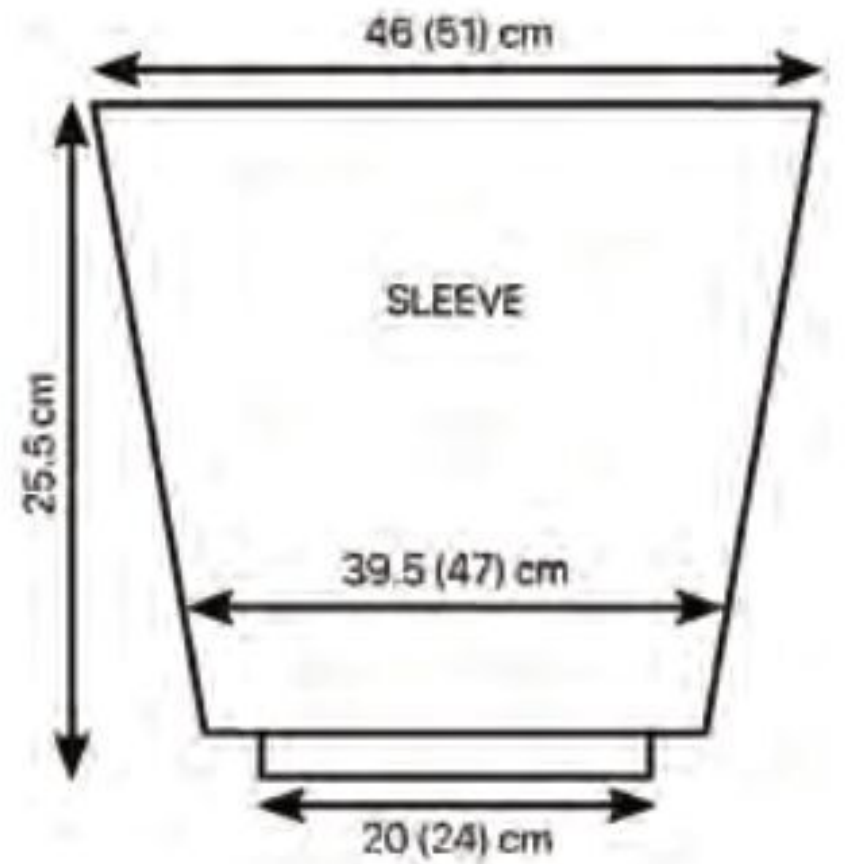
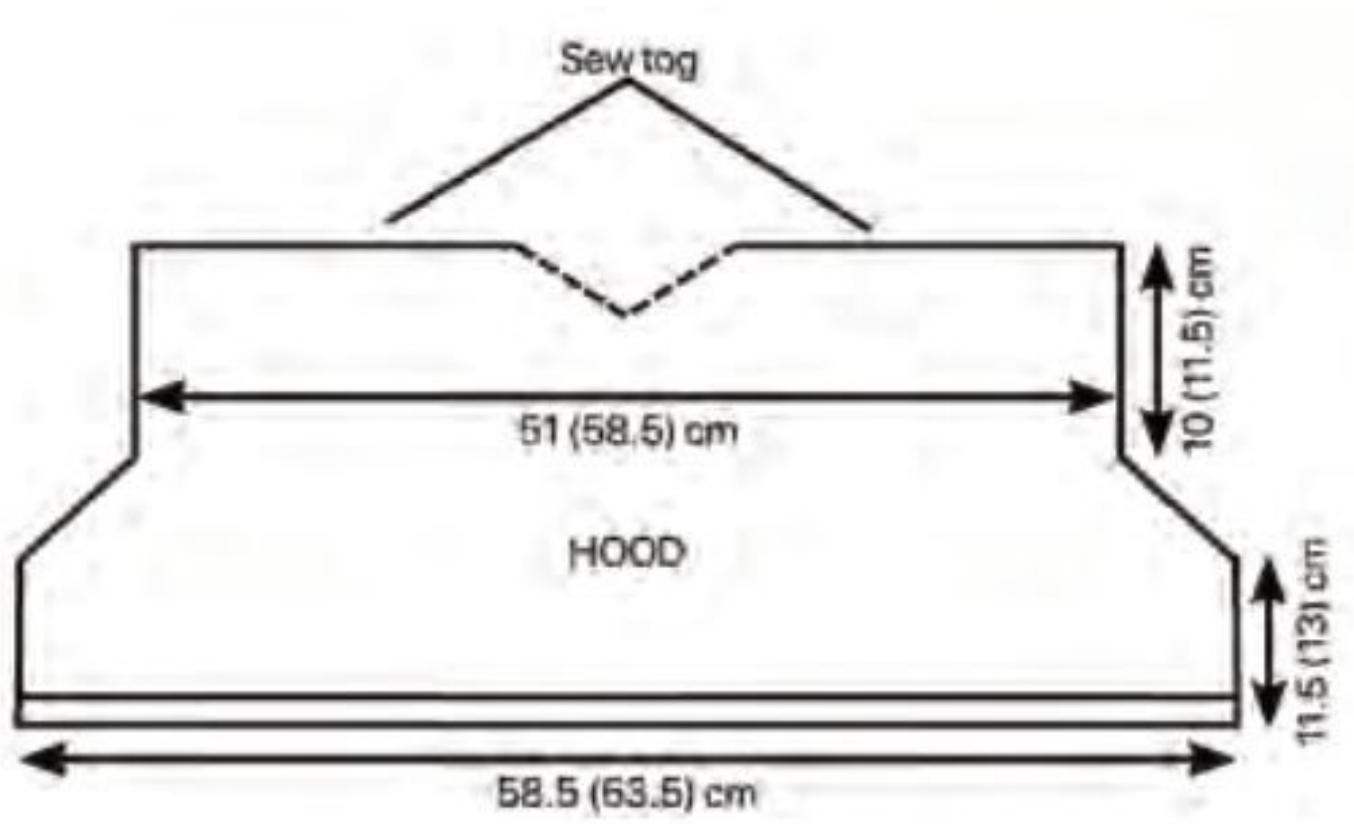
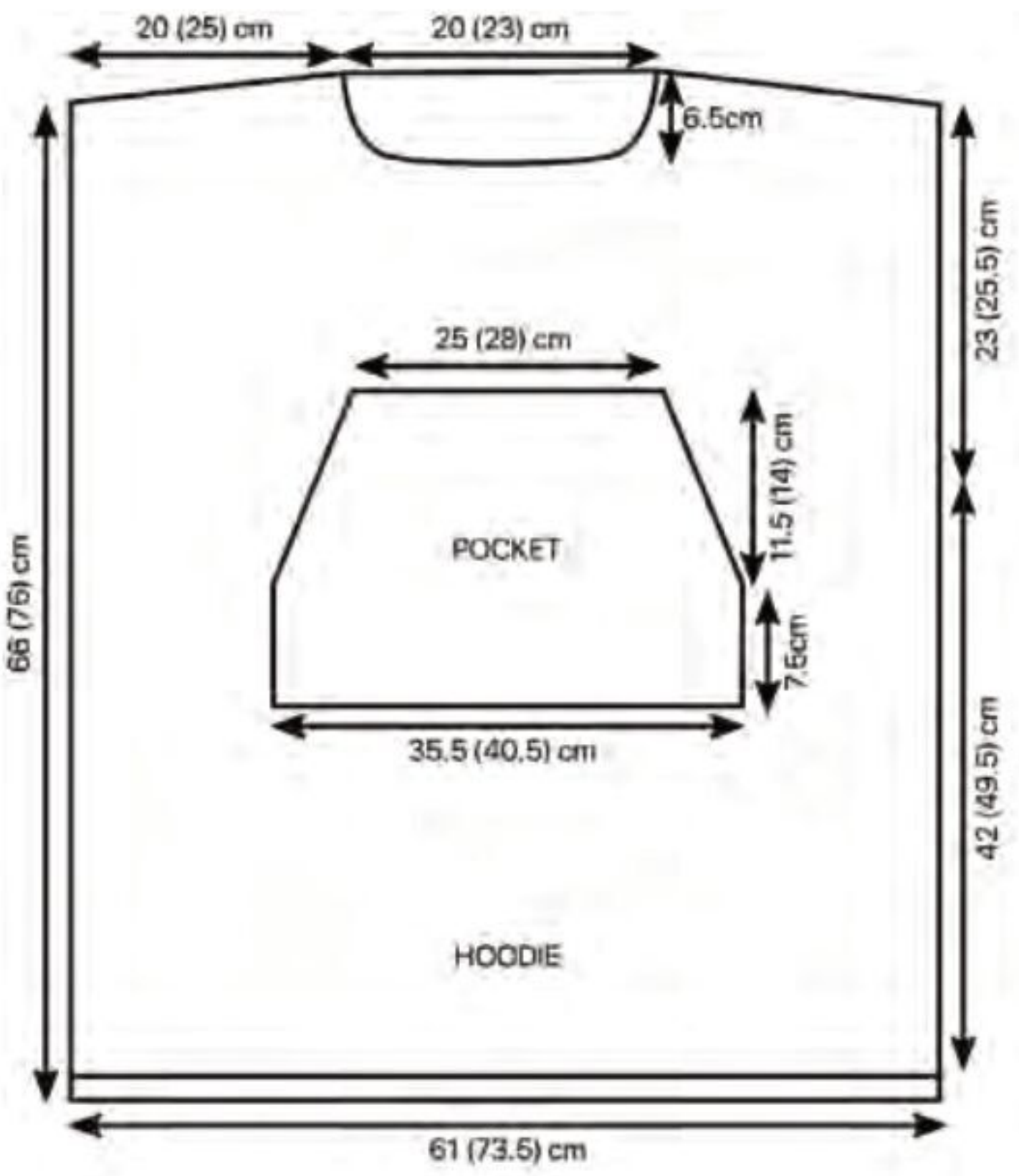

Beg 2 ch does not count as st, join all rnds with sl st to beg htr.

Start crocheting...

Body

With CC, ch 120 (144), join with sl st in first ch to beg working in the rnd, being careful not to twist chain. Pm for beg of rnd.

Rnd 1 (RS): 2 ch, htr around, join. Turn.

Rnd 2 (WS): 2 ch, RtrF around, join with MC. Fasten off CC. Turn.

Rnd 3 (RS): With MC, 2 ch, htr around, join. Turn.

Rnd 4 (WS): 2 ch, htr around, join. Turn. Rep last 2 rnds until work from beg measures 43 (51) cm, ending on a WS rnd. Turn.

Divide for Back and Front

Back

Row 1 (RS): 2 ch, 60 (72) htr, leave rem sts unworked. Turn.

Row 2: 2 ch, htr across. Turn. Rep last row until armhole measures 23 (25.5) cm, ending on a WS row. Turn.

Shape shoulders

Row 1: Sl st in first 10 (12) sts, 1 ch, htr across to last 9 (11) sts, 1 dc, leave rem 8 (10) sts unworked. Turn. 42 (50) htr

Row 2: Sl st in first 10 (13) sts, 1 ch, htr across to last 9 (12) sts, 1 dc, leave rem sts unworked. Fasten off. 24 (26) htr

Front

Row 1: With RS facing join MC with sl st in first unworked st, starting in same st as join, 60 (72) htr. Turn.



Row 2: 1 ch, htr across. Turn.
Rep last row until armhole measures 6 rows shorter than Back before beg of shoulder shaping, ending on a WS row.

Shape left neck

Row 1 (RS): 2 ch, 20 (25) htr, 1 htr2tog, 1 htr, leave rem sts unworked. Turn. 22 (27) sts
Row 2: 2 ch, 1 htr, 1 htr2tog, htr to end of row. Turn. 21 (26) sts
Row 3: 2 ch, htr across to last 3 sts, 1 htr2tog, 1 htr. Turn. 20 (25) sts
Rows 4-6: 2 ch, htr across. Turn.

Shape shoulder

Row 7 (RS): Sl st in first 10 (12) sts, 1 ch, htr to end of row. Fasten off.

Shape right neck

With RS facing, miss next 14 (16) htr (centre front neck), join MC with sl st in next htr. Cont on rem 23 (28) sts as follows:

Row 1 (RS): 2 ch, 1 htr, 1 htr2tog, htr to end of row. Turn. 22 (27) sts
Row 2: 2 ch, htr across to last 3 sts, 1 htr2tog, 1 htr. Turn. 21 (26) sts
Row 3: As Row 1. 20 (25) sts
Rows 4-5: 1 ch, htr across. Turn.

Shape shoulder

Row 7 (WS): Sl st in first 10 (12) sts, 1 ch, htr to end of row. Fasten off.

Sleeves

Sew shoulder seams.

With RS facing, join MC at side edge between Left Front and Back.

Rnd 1 (RS): 2 ch, work 45 (53) htr evenly around armhole, join. Pm for beg of rnd. Turn.

Rnds 2-6: 2 ch, htr around, join. Turn.

Rnd 7 (RS): 2 ch, 1 htr2tog, htr across to last 2 sts, 1 htr2tog, join. Turn. 43 (51) sts

Rnds 8-10: As Rnd 2.

Rep last 4 rnds twice more. 39 (47) sts

Cont as Rnd 2 until work from beg of Sleeve measures 23cm, ending on a RS rnd.

Next Rnd (WS): 2 ch, 1 htr, 19 (23) htr2tog, join with CC. Fasten off MC. Turn. 20 (24) sts

Next Rnd (RS): With CC, 2 ch, htr around. Turn.

Next Rnd: 2 ch, RtrF around, join. Fasten off.

Hood

With CC, chain 59 (65) loosely.

Row 1 (RS): Starting in 3rd ch from hook, htr across. Turn. 57 (63) sts

Row 2: 2 ch, RtrF to end of row, join MC.

Fasten off CC. Turn.

Row 3: With MC, 2 ch, htr to end of row. Turn.

Rep last row until work from beg measures 11.5 (12.5) cm, ending on a WS row.

Shape Neck of Hood

Row 1 (RS): 2 ch, 1 htr, 1 htr2tog, htr across to last 3 sts, 1 htr2tog, 1 htr. Turn. 55 (61) sts

Row 2: 2 ch, htr to end of row. Turn.
Rep last 2 rows twice more and pm at end of last row. 51 (57) sts

Rep Row 2 until work from marked row measures 5cm, ending on a WS row.

Shape back of Hood

Row 1 (RS): 2 ch, 23 (26) htr, 1 htr2tog, 1 htr, pm in last htr, 1 htr2tog, htr to end of row. Turn. 49 (55) sts



Row 2: 2 ch, htr across to 2 sts before marked st, 1 htr2tog, 1 htr, pm, 1 htr2tog, htr to end of row. Turn. 47 (53) sts
Rep last row 2 (3) times more. 43 (47) sts
Fasten off.

Fold last row in half and sew back seam. Overlap fronts of Hood at foundation row by 4cm (overlap will be centre front). Sew Hood around neck opening, matching Hood seam with centre back neck edge.

Pocket

With MC, chain 37 (42).

Row 1 (RS): Starting in 3rd ch from hook, htr across. Turn. 35 (40) htr

Row 2: 2 ch, htr to end of row. Turn.
Rep last row until work from beg measures 7.5cm, ending on a WS row.

Shape sides

Row 1 (RS): 2 ch, 1 htr, 1 htr2tog, htr across to last 3 sts, 1 htr2tog, 1 htr. Turn. 33 (38) sts

Row 2: 2 ch, htr to end of row. Turn.
Rep last 2 rows 3 (4) times more, then rep Row 1 once more. 25 (28) sts
Fasten off.

Try on Hoodie. Pin Pocket at comfortable height on centre front. Sew Pocket edges in position, leaving shaped sides open.

Outer Ears (make 2)

With MC, chain 10.

Row 1 (RS): Starting in 3rd ch from hook, htr across. Turn. 8 htr

Rows 2-6: 2 ch, htr to end of row. Turn.

Shape top of Ears

Row 7 (RS): 2 ch, 1 htr2tog, 4 htr, 1 htr2tog. Turn. 6 sts

Row 8: 2 ch, 1 htr2tog, 2 htr, 1 htr2tog. Turn. 4 sts

Row 9: 2 ch, 2 htr2tog. Turn. 2 sts

Row 10: 2 ch, 1 htr2tog. Fasten off.

Inner Ears (make 2)

With A, work as given for Outer Ears.

With WS of Outer and Inner Ears tog, join MC with sl st at foundation ch. Working through both thicknesses, work in dc around Ears to opposite side of foundation ch, having 2 dc at top point. Fasten off, leaving a long tail. Fold foundation row in half. Sew to Hood using photograph as a guide.

Mane

Cut strands of MC and CC 15cm long.

Holding 2 strands each MC and CC tog, fold in half and knot into fringe across centre of Hood. Trim fringe evenly. 🧶

CARON[®]
SIMPLY
SOFT[®]



50 COLOURS | 100% ACRYLIC
ARAN WEIGHT | NO DYE LOTS

NOW AVAILABLE FROM
WOOL WAREHOUSE | THE RANGE
READICUT | OH SEW CRAFTY



Sarah-Jayne

Bella Coco CROCHET CHRONICLES

With the days getting lighter, Sarah-Jayne is starting to look forward to spring!

www.bellacococrochet.com

www.crochetsociety.co.uk

Now the festive season is well and truly behind us, it is time to start looking towards the new beginnings that 2022 has to offer. I say this year after year... but spring is my thing! I love the lighter mornings, fresh buds blooming and the prospect of new beginnings. I don't think I'm alone in seeing spring as a chance to

start something fresh and new; after all, we don't get the 'spring cleaning' bug for no reason.

I often get oodles of ideas around this time. Far too many ideas to handle, in fact! So maybe a way to scratch the inspiration itch is to do lots of smaller projects rather

than diving into bigger ones.

When I think of spring and new beginnings, cute little bunnies are one of the first things to pop into my head. With that being said, I thought I would share this little Bunny Appliqué pattern with you!



Small... check.
Quick... check.
Super cute.... check!

It's a win on all levels I think! These appliqués look great on their own or strung together to make a springtime garland. If you know me, I gravitate towards pastel colours, but these would also look just as good in neutrals or bright colours.



 DK  4mm

★ Quick & easy

Yarn used

Stylecraft Special DK
2 balls in your chosen colour

Visit www.woolwarehouse.co.uk
to find your local stockist

About the yarn

DK; 295m per 100g ball; 100% Acrylic

Hook used

4mm

Tension

Tension is not critical for this project

Sizing

Approximately 13cm in diameter
.....

 Start crocheting...

BUNNY BODY

Rnd 1: With coloured yarn, starting with a magic circle, work 6 dc in circle, pull circle tail tight, sl st into first dc. *6 dc*

Rnd 2: 1 ch, work 2 dc in each st around, sl st into 1 ch. *12 dc*

Rnd 3: 1 ch, 1 dc into first st, 2 dc into next st, (1 dc in next st, 2 dc in next st) around, sl st into first dc. *18 dc*

Rnd 4: 1 ch, 1 dc in each of first 2 sts, 2 dc in next st, (dc in next 2 sts, 2 dc in next st) around, sl st into first dc. *24 dc*

BUNNY HEAD

1 ch, work 1 htr into first st, tr in next st, dtr in next 4 sts, tr in next st, htr in next st, 1 ch, sl st into next st, sl st in each st around.

EARS

Sl st in htr, sl st in tr, sl st in first dtr, *5 ch, in second ch from hook work htr, tr in next 3 chs,* sl st into top of third dtr from previous round, repeat from * to * sl st into htr after fourth dtr in previous round, 1 ch, sl st in next st, yrh and cut yarn with long tail.

SEWING EARS

Attach tail to needle. From back side of bunny, sew through the bottom - most tr



Crochet Bunny APPLIQUE

Hop to it and hook up one of these adorable appliqué bunnies!

of each ear to the head round to close the gap between the ears and the body. Secure tail on back side. Weave in beginning tail.

TAIL

With cream or white yarn, leaving a long tail begin with a slipknot on hook, 2 ch, *yrh, insert hook into first ch, yrh, pull through, yrh, draw through 2 loops on hook; repeat from * three times so that there are 5 loops from hook, yrh, pull through all loops on hook, 1 ch to tighten stitch. Leaving a long tail, cut yarn and pull through loop on hook.

ATTACHING TAIL

Insert hook in spaces of first round (not centre of bunny), take one tail and pull through. Position tail as you like it, insert



hook and pull opposite tail through body. Tie a knot or two in tails on back side of bunny. 



Andreia Ferreira

PUFFY THE CLOUD TOY

Puffy the Cloud loves to fly high in the sky and slide down rainbows!
Bring this adorable ball of fun into your home tonight!

 DK  3mm

★★ Intermediate

Yarn used

Ricorumi DK
2 balls in white 001 (MC)
1 ball each in pink 011 (CC1), Lotus 067 (CC2),
pastel yellow 062 (CC3), pastel green 045
(CC4), light blue 033 (CC5) & lilac 017 (CC6)
Available at www.woolwarehouse.co.uk

About the yarn

DK; 57.5m per 25g ball; 100% cotton

Tension

30 sts x 25 rows = 10cm measured over dc

Hook used

3mm

Other supplies

toy stuffing
tapestry needle
stitch markers
sewing pins

Sizing

14cm

When making amigurumi dolls, always aim for tight stitches. A good way to do so without exhausting your hands is to make an "x" double crochet, by doing yarn under and then yarn over when working the stitch.

Sewing pins can be very handy; make sure to use them to place the pieces in the correct position before you start sewing.

To sew a hole closed of a stuffed piece, run the yarn tail through the needle and with it

pick up all the front loops of the last round worked. Pull tightly to close the hole and hide the yarn tail inside the piece.

The main parts of this pattern are worked in the amigurumi style, in a spiral without slip stitching or turning chains. Use a stitch marker or waste yarn to keep track of the first stitch of each round.

The scarf is worked in rows, turn your work at the end of the row, turning chains do not count as a stitch.

Start crocheting...

Head

Rnd 1: With MC and working into a magic ring, 6 dc. 6 sts

Rnd 2: 2 dc in each st to end. 12 sts

Rnd 3: *1 dc, 2 dc in next st; rep from * to end. 18 sts

Rnd 4: *2 dc, 2 dc in next st; rep from * to end. 24 sts

Rnd 5: *3 dc, 2 dc in next st; rep from * to end. 30 sts

Rnds 6-8: Dc around.

Rnd 9: 12 dc, [2 dc in FLO of next st] 6 times, dc to end. 36 sts

Rnd 10: 12 dc, [1 dc, 2 dc in next st] 6 times, dc to end. 42 sts

Rnds 11-15: Dc around.

Rnd 16: 12 dc, [1 dc, 1 dc2tog] 6 times, dc to end. 36 sts

Rnd 17: 12 dc, [1 dc, 2 dc in next st] 6 times, dc to end. 42 sts

Rnd 18: 12 dc, [2 dc, 2 dc in next st] 6 times, dc to end. 48 sts

Rnds 19-24: Dc around.

Rnd 25: 12 dc, [2 dc, 1 dc2tog] 6 times, dc to end. 42 sts

Rnd 26: 12 dc, [1 dc, 1 dc2tog] 6 times, dc to end. 36 sts

Rnd 27: 12 dc, 6 dc2tog, 12 dc. 30 sts
Beg to stuff firmly and cont as you go.

Rnd 28: 12 dc, 6 dc in FLO, 12 dc.

Rnds 29-30: Dc around.

Rnd 31: *3 dc, 1 dc2tog; rep from * to end. 24 sts

Rnd 32: *2 dc, 1 dc2tog; rep from * to end. 18 sts

Rnd 33: *1 dc, 1 dc2tog; rep from * to end. 12 sts

Rnd 34: 6 dc2tog. 6 sts

Fasten off, leaving a long tail. Sew hole closed with tail.

With CC3 and using photo as a guide, embroider the eyes 2 sts tall with the right eye between rnds 12 and 16, and the left eye between rnds 21 and 25. Try to embroider them at the same level and near the middle of the Head's height. Embroider a few lashes for each eye. With CC5, embroider a mouth between the eyes, 3 rnds wide.

Cheeks (make 2)

Rnd 1: With CC1 and working into a magic ring, 5 dc. 5 sts

Rnd 2: 2 dc in each st to end. 10 sts



Toy

Sl st in next st to close spiral.
Fasten off, leaving a long tail for sewing.
Sew Cheeks slightly below the eyes and 1 st away from them on either side.

Body

Rnd 1: With MC and working into a magic ring, 6 dc. 6 sts

Rnd 2: 2 dc in each st to end. 12 sts

Rnd 3: *1 dc, 2 dc in next st; rep from * to end. 18 sts

Rnd 4: *2 dc, 2 dc in next st; rep from * to end. 24 sts

Rnd 5: *3 dc, 2 dc in next st; rep from * to end. 30 sts

Rnd 6: *4 dc, 2 dc in next st; rep from * to end. 36 sts

Rnd 7: *5 dc, 2 dc in next st; rep from * to end. 42 sts

Rnd 8: *6 dc, 2 dc in next st; rep from * to end. 48 sts

Rnd 9: *7 dc, 2 dc in next st, rep from * to end. 54 sts

Rnds 10-13: Dc around.

Rnd 14: *7 dc, 1 dc2tog; rep from * to end. 48 sts

Rnds 15-16: Dc around.

Rnd 17: *6 dc, 1 dc2tog; rep from * to end. 42 sts

Rnds 18-19: Dc around.

Rnd 20: *5 dc, 1 dc2tog; rep from * to end. 36 sts

Rnd 21-22: Dc around.

Rnd 23: *4 dc, 1 dc2tog; rep from * to end. 30 sts

Rnds 24-25: Dc around.

Fasten off, leaving a long tail for sewing.
Stuff Body firmly and flatten the bottom to sit on a surface. Pinch the opening to match the width of Head. Sew Body to Head between rnds 14 and 24.

Legs (make 2)

Rnd 1: With MC and working into a magic ring, 6 dc. 6 sts

Rnd 2: 2 dc in each st to end. 12 sts

Rnd 3: *1 dc, 2 dc in next st; rep from * to end. 18 sts

Rnd 4: *2 dc, 2 dc in next st; rep from * to end. 24 sts

Rnds 5-10: Dc around.

Fasten off, leaving a long tail for sewing.
Stuff firmly. Sew Legs to each side of Body between rnds 7 and 14, with 8 sts between them at the front.

Arms (make 2)

Rnd 1: With MC and working into a magic ring, 6 dc. 6 sts

Rnd 2: 2 dc in each st to end. 12 sts

Rnd 3: *3 dc, 2 dc in next st; rep from * to end. 15 sts

Rnds 4-13: Dc around.

Rnd 14: *3 dc, 1 dc2tog; rep from * to end. 12 sts

Stuff lightly.

Flatten the opening and work 6 dc through both layers to close.

Fasten off, leaving a long tail for sewing.

Sew Arms on each side of Body between rnds 19 and 24 and secure them with a stitch where they touch the Legs.

Scarf

Change colours on last yrh of last st before

colour change.

With CC1, chain 101.

Row 1: Starting in 2nd ch from hook and working in back bumps, dc across. Turn. 100 sts

Change to CC2

Row 2: 1 ch, dc across. Turn.

Change to CC3

Row 3: 1 ch, dc across. Turn.

Change to CC4

Row 4: 1 ch, dc across. Turn.

Change to CC5

Row 5: 1 ch, dc across. Turn.

Change to CC6

Row 6: 1 ch, dc across.

Fasten off. Weave in ends. 🧶

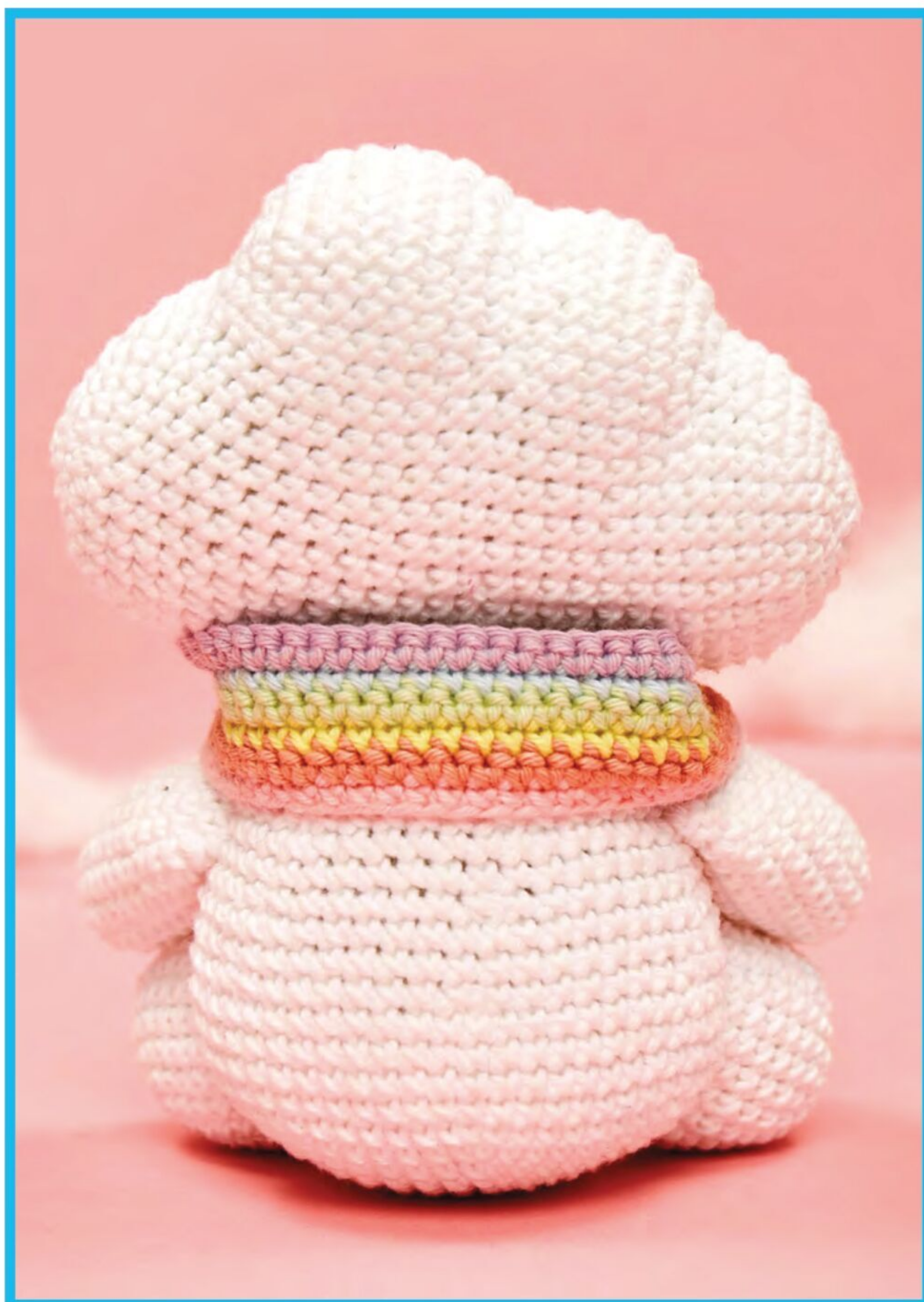



**Family Owned
Since 1987**

CASCADE YARNS[®]

Ecological Wool[®]

100% Wool



**Katrina
Cable Wrap**

by Bonnie Barker
Free Pattern C290



www.cascadeyarns.com

SAVE & WIN!

Win a year of yarn from Wool Warehouse!



The generous team at Wool Warehouse is giving one lucky *Crochet Now* reader a whole year of yarn! You will never be short of inspiration (or yarn!) with this unbelievable bundle. There are 52 balls of yarn to be had from a whole range of top brands. With a beautifully curated mix of shades, we know the winner of this giveaway will always have the right colour for any project. Stock up your stash with this amazing Wool Warehouse giveaway!
www.woolwarehouse.co.uk

UPGRADE YOUR CRAFT ROOM

Store all your sewing supplies, tools and gadgets in style with the incredible Storage4Crafts Allstore Storeaway Knightshayes 2.0 craft unit. It offers a table for sewing machines, a large number of boxes, drawers and devices to keep your crafty bits and pieces beautifully organised. This fold-away wooden workstation unit is perfect for adapting to your latest project – the possibilities really are endless.

**WORTH
£3,099!**

Enter now for your chance to win this impressive organiser and find out more at www.storage4crafts.com



**For your chance to win, enter online at
www.craftworld.com/cms/crochet-now by 18th January 2022**

We promise we'll always keep your data safe and will never share it with or sell it to other companies for marketing purposes. Our full privacy policy is available at www.practicalpublishing.co.uk/privacy. The competition is operated by Practical Publishing International Ltd. For full terms and conditions, see www.practicalpublishing.co.uk/competitions

FREE CROCHET SOCIETY COCO CUSHION CAL

WHEN YOU SUBSCRIBE TO **crochet**
now



Brand-new
CAL
worth
£34.99

Join Crochet Now and receive this stunning Crochet Society Coco Cushion CAL. It contains nine balls of exclusive yarn, a tote bag and soft notebook. PLUS weekly online videos will help you every step of the way to make this gorgeous squishy cushion!

crochet
society

How to pay:

£18.99 EVERY 3 MONTHS
£75.99 FOR 13 ISSUES

BEST
OPTION



How to order:

Online: www.practicalsubs.com/7306

Call: 0161 327 0441

(Quote code: PLCRG077)



 Aran  5mm

★★★ Advanced

Yarn used

Scheepjes Stone Washed XL
1 ball each in Lemon Quartz 852 (A), Lilac Quartz 858 (B), Tourmaline 876 (C), Moon Stone 841 (D), Amazonite 853 (E) & Forsterite 866 (F)
Visit www.scheepjes.com to find your local stockist

About the yarn

Aran; 75m per 50g ball; 70% cotton, 30% acrylic

Hook used

5mm

Tension

3 rnds = 9cm

Other supplies

stitch marker

Sizing

30.5cm along each side

When working overlay crochet, work in front of all the previous rounds rather than enclosing them.

Beg 3 ch counts as first tr.

Beg 1 ch does not count as a st.

Start crocheting...

Join at end of rnd with sl st to beg st, unless otherwise stated.

Rnd 1: With A and working into a magic ring, 3 ch, 11 tr, join with sl st in top of beg 3 ch. Fasten off. 12 sts

Rnd 2: Join B with sl st in any st, 1 beg PS, 1 ch, *1 PS in next st, 1 ch; rep from * to end, join. Fasten off. 12 sts

Rnd 3: Join A with sl st in any 1ch-sp, 5 ch (counts as first tr, 2 ch), 1 tr in same sp, miss 1 st, *[1 tr, 2 ch, 1 tr] into next 1ch-sp, miss 1 st; rep from * to end, join with sl st in 3rd ch of beg 5 ch. Fasten off. 24 sts

Rnd 4: Join C with sl st in any 2ch-sp, 1 ch, [1 htr, 2 tr, 2 ch, 2 tr, 1 htr] in same 2ch-sp as join, miss 1 tr, 1 RtrF around PS in Rnd 2 below, miss 1 tr, *[1 htr, 2 tr, 2 ch, 2 tr, 1 htr] into next 2ch-sp, miss 1 tr, 1 RtrF around PS in Rnd 2 below, miss 1 tr; rep

Special stitches

Beginning Puff Stitch (begPS): Sl st in indicated st, pul on hook, [yrh, insert hook in same st, yrh, pul] 4 times, yrh, draw through all 9 loops on hook, 1 ch to close

Puff stitch (PS): [Yrh, insert hook in indicated st, yrh, pul] 4 times in same st, yrh, draw through all 9 loops on hook, 1 ch to close

Beginning 2 treble cluster (beg 2trcl): Sl st in indicated st, 2 ch, yrh, insert hook into same st, yrh, pul, yrh, draw through 2 loops, yrh, draw through all 2 loops on hook

2 treble cluster (2trcl): [Yrh, insert hook in indicated st, yrh, pul, yrh, draw through 2 loops] twice into same st, yrh, draw through all 3 loops on hook

Beginning 3 treble cluster (Beg 3trcl): Sl st in indicated st, 2 ch, [yrh, insert hook

into same st, yrh, pul, yrh, draw through 2 loops] twice, yrh, draw through all 3 loops on hook

3 treble cluster (3trcl): [Yrh, insert hook in indicated st, yrh, pul, yrh, draw through 2 loops] 3 times into same st, yrh, draw through all 4 loops on hook

Picot: 3 ch, sl st through front loop and loop directly below (on post of st) on st just made

Raised double treble Front (RdtrF): Work the double treble around the post of the st inserting hook from front to back around to front again

Popcorn (PC): Make 5 tr in indicated st, remove hook from loop, insert hook from front to back in first st made, replace loop on hook and pull through st, 1 ch to secure

Blooming Blossoms

WALL HANGING

Learn multiple new stitches by hooking up this beautiful wall hanging using colourful yarn to brighten your home

Designed by *Inas Fadil Basymeleh*

from * to end, join. Fasten off. *84 sts*

Rnd 5: Join D with sl st in any 2ch-sp, 1 ch, 1 dc into same sp, 5 ch, miss 7 sts, *1 dc into next 2ch-sp, 5 ch, miss 7 sts; rep from * to end, join. Do not fasten off. *12 sts*

Rnd 6: 1 ch, 1 htr in first st, [1 htr, 4 dc (pm in first dc made)] into next 5ch-sp, 1 dc in next st, [4 dc, 1 htr] into next 5ch-sp, 1 htr in next st, 7 tr into next 5ch-sp, *1 htr in next st, [1 htr, 4 dc] into next 5ch-sp, 1 dc in next st, [4 dc, 1 htr] into next 5ch-sp, 1 htr in next st, 7 tr into next 5ch-sp; rep from * to end, join. Fasten off. *80 sts*

Rnd 7: Join B with sl st in marked dc, 1 ch, 1 dc in same st, 3 dc, miss 1 dc, 1 RtrF around dc of Rnd 5 below, 4 dc, 1 ch, miss 2 htr, [1 2trcl, 1 ch] 7 times (pm in 1ch-sp after first cl), miss 2 htr, *4 dc, miss 1 dc, 1 RtrF around dc of Rnd 5 below, 4 dc, 1 ch, miss 2 htr, [1 2trcl, 1 ch] 7 times, miss 2 htr; rep from * to end, join. Fasten off. *64 sts*

Rnd 8: Join E with sl st in marked 1ch-sp, 3 ch, 2 tr in same sp as join, [miss 1 cl, 3 tr into next 1ch-sp] 5 times, miss 1 cl, 1 tr into next 1ch-sp, miss 2 dc, [1 3trcl, 2 ch (pm in 2ch-sp), 1 3trcl] in next st, 1 ch, miss [1 dc, 1 RtrF, 1 dc], [1 3trcl, 2 ch, 1 3trcl] in next st, miss 2 dc, 1 tr into next 1ch-sp, miss 1 cl, *3 tr into next 1ch-sp, [miss 1 cl, 3 tr into next 1ch-sp] 5 times, miss 1 cl, 1 tr into next 1ch-sp, miss 2 dc, [1 3trcl, 2 ch, 1 3trcl] in next st, 1 ch, miss [1 dc, 1 RtrF, 1 dc], [1 3trcl, 2 ch, 1 3trcl] in next st, miss 2 dc, 1 tr into next 1ch-sp, miss 1 cl; rep from * to end, join with sl st in top of beg 3 ch. Fasten off. *96 sts*

Rnd 9: Join F with beg 3trcl in marked 2ch-sp, 2 ch, 1 3trcl into same sp, miss [1 cl, 1 ch], 1 RdtrF around RtrF of Rnd 7 below, miss 1 cl, [1 3trcl, 2 ch, 1 3trcl] into next 2ch-sp, 1 ch, miss [1 cl, 1 tr], working in

BLO, 6 dc, miss 2 tr, [1 2trcl, 2 ch, 1 2trcl] in next st, 2 ch (pm), [1 2trcl, 2 ch, 1 2trcl] in next st, miss 2 tr, 6 dc, 1 ch, miss [1 tr, 1 cl], *[1 3trcl, 2 ch, 1 3trcl] into next 2ch-sp, miss [1 cl, 1 ch], 1 RdtrF around RtrF of Rnd 7 below, miss 1 cl, [1 3trcl, 2 ch, 1 3trcl] into next 2ch-sp, 1 ch, miss [1 cl, 1 tr], 6 dc, miss 2 tr, [1 2trcl, 2 ch, 1 2trcl] in next st, 2 ch, [1 2trcl, 2 ch, 1 2trcl] in next st, miss 2 tr, 6 dc, 1 ch, miss [1 tr, 1 cl]; rep from * to end, join. Fasten off. *84 sts*

Rnd 10: Join A with beg 2trcl in marked 2ch-sp, 3 ch, 1 2trcl into same sp, miss 1 cl, [1 2trcl, 2 ch (pm), 1 2trcl] into next 2ch-sp, miss [1 cl, 1 dc], [1 2trcl, 1 ch, 1 2trcl] in next st, miss 2 dc, [1 2trcl, 1 ch, 1 2trcl] in next st, miss [1 dc, 1ch-sp], 1 RdtrF around missed tr in Rnd 8, miss 1 cl, [1 3trcl, 2 ch, 1 3trcl] into next 2ch-sp, 1 ch, miss [1 cl, 1 RdtrF, 1 cl], [1 3trcl, 2 ch, 1 3trcl] into next 2ch-sp, miss 1 cl, 1 RdtrF around missed tr in Rnd 8, miss [1ch-sp, 1 dc], [1 2trcl, 1 ch, 1 2trcl] in next st, miss 2 dc, [1 2trcl, 1 ch, 1 2trcl] in next st, miss [1 dc, 1 cl], [1 2trcl, 2 ch, 1 2trcl] into next 2ch-sp, miss 1 cl, *[1 2trcl, 3 ch, 1 2trcl] into next 2ch-sp, miss 1 cl, [1 2trcl, 2 ch, 1 2trcl] into next 2ch-sp, miss [1 cl, 1 dc], [1 2trcl, 1 ch, 1 2trcl] in next st, miss 2 dc, [1 2trcl, 1 ch, 1 2trcl] in next st, miss [1 dc, 1 ch-sp], 1 RdtrF around missed tr in Rnd 8, miss 1 cl, [1 3trcl, 2 ch, 1 3trcl] into next 2ch-sp, 1 ch, miss [1 cl, 1 RdtrF, 1 cl], [1 3trcl, 2 ch, 1 3trcl] into next 2ch-sp, miss 1 cl, 1 RdtrF around missed tr in Rnd 8, miss [1ch-sp, 1 dc], [1 2trcl, 1 ch, 1 2trcl] in next st, miss 2 dc, [1 2trcl, 1 ch, 1 2trcl] in next st, miss [1 dc, 1 cl], [1 2trcl, 2 ch, 1 2trcl] into next 2ch-sp, miss 1 cl; rep from * to end, join. Fasten off. *80 sts*

Rnd 11: Join C with sl st in marked 2ch-sp, 3 ch (pm), 1 tr in same sp, [2 RtrF, 1 tr into

next 1ch-sp] twice, 2 RtrF, miss 1 cl, [1 PC, 1 ch, 1 PC] into next 2ch-sp, miss [1 cl, 1ch-sp], 1 RdtrF around missed RdtrF in Rnd 9, miss 1 cl, [1 PC, 1 ch, 1 PC] into next 2ch-sp, miss 1 cl, 2 RtrF, [1 tr into next 1ch-sp, 2 RtrF] twice, 2 tr into next 2ch-sp, 2 RtrF, [1 PC, 2 ch, 1 PC] into next 3ch-sp, 2 RtrF, *2 tr into next 2ch-sp, [2 RtrF, 1 tr into next 1ch-sp] twice, 2 RtrF, miss 1 cl, [1 PC, 1 ch, 1 PC] into next 2ch-sp, miss [1 cl, 1ch-sp], 1 RdtrF around missed RdtrF in Rnd 9, miss 1 cl, [1 PC, 1 ch, 1 PC] into next 2ch-sp, miss 1 cl, 2 RtrF, [1 tr into next 1ch-sp, 2 RtrF] twice, 2 tr into next 2ch-sp, 2 RtrF, [1 PC, 2 ch, 1 PC] into next 3ch-sp, 2 RtrF; rep from * to end, join with sl st in top of beg 3 ch. Fasten off. *124 sts*

Rnd 12: Join D with sl st in top of marked beg ch, 3 ch, 8 tr, 1 RtrF, 1 RhtrF, 2 htr into next 1ch-sp, 1 RhtrF, 1 RtrF, 1 RhtrF, 2 htr into next 1ch-sp, 1 RhtrF, 1 RtrF, 10 tr, 2 RdtrF, [3 dtr, 2 ch, 3 dtr] into next 2ch-sp, 2 RdtrF, 1 tr, *9 tr, 1 RtrF, 1 RhtrF, 2 htr into next 1ch-sp, 1 RhtrF, 1 RtrF, 1 RhtrF, 2 htr into next 1ch-sp, 1 RhtrF, 1 RtrF, 10 tr, 2 RdtrF, [3 dtr, 2 ch, 3 dtr] into next 2ch-sp, 2 RdtrF, 1 tr; rep from * to end, join with sl st in top of beg 3 ch. *164 sts*

Rnd 13: 1 ch, 1 dc in first st, 34 dc, *[2 dc, 1 picot, 2 dc] into next 2-ch sp, 3 dc, 1 picot, [5 dc, 1 picot] 7 times, 3 dc, [2 dc, 1 picot, 2 dc] into next 2-ch sp*, 41 dc; rep between * and * once more, 6 dc, join. Fasten off. *180 sts*

Finishing

Weave in ends and block. Make 10 (2 for each of colours B-F) 7.5cm tassels. Attach one tassel in each picot on bottom of square. Weave in rem ends and slide dowel through top to use as hanger. 

Mark the first and last st on each row to find them more easily in the next row



Join our CAL
Facebook group!
www.facebook.com/groups/enigmacrochetalong



Esther Dijkstra

Enigma

CROCHET-ALONG PART 10

This month we are adding beautiful floral details to our blankets, as we continue onto Part 10!

www.itsallinanutshell.com

Two identical panels are worked on opposite sides of the square. The positioning of the flowers is random, so feel free to place them according to your liking.

Beg 3 ch counts as first tr.

Beg 1 ch does not count as a st.

Special stitches

Standing RtrB: With slipknot on hook, RtrB around indicated st

RhtrB: Work the htr around the post of the st, inserting hook from back to front to back again

Start crocheting...

Row 1 (RS): Join C with sl st in any corner 2ch-sp, 3 ch, 182 tr, 1 tr in ch2-sp. Turn. 184 tr

Row 2 (WS): 3 ch, 183 tr. Turn. 184 tr

Rows 3-4: Rep Row 2.

Row 5: Rep Row 2. Do not turn. Fasten off.

Row 6 (RS): Join E with sl st in first st, 1 ch, 184 htr. Do not turn. Fasten off. 184 htr

Row 7 (RS): Join A with standing RhtrB around first st, 183 RhtrB. Fasten off. 184 RhtrB

Rep rows 1-7 on the opposite side of the blanket to make a second identical panel.



Sport or DK 3.5 or 4mm

★★ Learn something new

Yarn used

Scheepjes Stone Washed
6 balls in Moon Stone 801 (A)
5 balls in Malachite 825 (E)
4 balls each in Rose Quartz 820 (C),
Carnelian 823 (D)
& Tourmaline 836 (G)
3 balls each in Coral 816 (B)
& Beryl 833 (F)

Scheepjes Colour Crafter
3 balls each in Barneveld 1005 (A)
& Malmédy 2014 (E)
2 balls each in Leeuwarden 1711 (B),
Sittard 1130 (C),
Maastricht 1246 (D),
Brussel 2004 (F)
& Luik 2006 (G)

Yarn packs available from
www.woolwarehouse.co.uk

or visit

www.scheepjes.com

to find your local
Scheepjes stockist

About the yarn

Stone Washed
Sport; 130m per 50g ball;
78% cotton, 22% acrylic

Colour Crafter
DK; 300m per 100g ball;
100% premium acrylic

Tension

Up to and including Rnd 6
measures 10cm diameter

Hooks used

3.5mm for Stone Washed
4mm for Colour Crafter

Other supplies

tapestry needle

Sizing

At end of part 10:
Stone Washed: Height of Part 10 is 6cm
Colour Crafter: Height of Part 10
is 7.5cm

Final size:

Stone Washed: 105x155cm
Colour Crafter: 115x170cm



Flowers

Centre (make 48)

With F, chain 4, join with sl st in 4th ch from hook to form a ring.

Rnd 1: Working into ring, 1 ch, 12 htr, join. Fasten off. 12 htr

Petals (make 24 in D and 12 each in B & G)

Rnd 1: Join with sl st in any st of flower centre, {[1 htr, 1 tr, 1 dtr, 1 tr, 1 htr] in next st, 1 sl st in next st} 6 times.

Fasten off, leaving a long tail for sewing. 6 petals

Leaving end tail for sewing, weave in ends. With tail, sew 24 flowers onto each panel. Place the flowers randomly over the fabric. Allow the flowers to fall over each other and over the edges of the panel.

Weave in any rem tails. 



SUBSCRIBE AND SAVE!

Subscribe to *Crochet Now* today to make sure you never miss a part of the Enigma CAL! Plus, by subscribing you save on the cover price of the magazine every month, receive your magazine before it hits the shops, and delivery is free! Turn to page 29 to find our exclusive, limited subscription offer!



Get your yarn!

Get your complete yarn pack from our partner below to make sure you have everything you need to complete either version of the Enigma blanket!

www.woolwarehouse.co.uk



SERIOUSLY CHUNKY



CROCHET YOUR WAY TO A WARMER WINTER WITH OUR SERIOUSLY CHUNKY

With bright bold shades & magnificently thick,
makes for quick fun filled projects

FOR MORE INFORMATION OR YOUR NEAREST STOCKIST PLEASE VISIT WWW.CYGNETYARNS.COM OR CALL 01274 743374



KnitPro
WAVES

Scan the QR code
to view our entire range



www.knitpro.eu



Victoria Barrett

UP IN THE CLOUDS JUMPER

Slip into spring with this beautifully delicate cropped jumper, that's equally comfortable and stylish

Sport & lace 5mm

★ Beginner friendly

Yarn used

Debbie Bliss Baby Cashmerino
5 (5, 6, 6, 7) (7, 9, 9, 10) balls in Silver 340012
Debbie Bliss Angel
3 (3, 3, 4, 4) (5, 5, 6, 6) balls in Ecrú 006
Available from www.lovecrafts.com

About the yarn

Cashmerino:
Sport; 125m per 50g ball; 55% wool,
33% acrylic, 12% cashmere
Angel:
Lace; 200m per 25g ball; 70%, mohair,
30% silk

Tension

14 sts x 7 rows = 10cm measured over tr with both yarns held tog

Hook used

5mm

Other supplies

6 stitch markers

Sizing

XS (S, M, L, 1X) (2X, 3X, 4X, 5X)

Chest circumference: 78.5 (87, 104.5, 113, 121.5) (130, 138.5, 155.5, 164.5) cm

Back waist length including ribbing:
43.5 (45, 45, 46.5, 46.5) (48, 48, 49.5, 49.5) cm

Sleeve length including ribbing: 32 (32, 32, 33.5, 33.5) (35, 35, 36.5, 36.5) cm

Sleeve circumference: 26.5 (26.5, 30.5, 35, 35) (39.5, 39.5, 43.5, 48) cm

Designed to fit with 5cm positive ease

Keep tension loose when working sl st ribbing to make the stitches easier to work into.

Use a yarn bowl or project bag to prevent both strands of yarn from tangling throughout the project.

Beg 3 ch counts as first tr.

Start crocheting...

This pattern is worked in flat panels, which are seamed tog before finishing with a sl st ribbing around the sleeve cuffs, neckline and waistband.

Body (make 2)

Holding one strand of each yarn tog, chain 57 (63, 75, 81, 87) (93, 99, 111, 117).

Row 1 (RS): Starting in 4th ch from hook, tr in back bump across. Turn. 55 (61, 73, 79, 85) (91, 97, 109, 115) sts

Row 2: 3 ch, 2 tr, *1 ch, miss 1 st, 5 tr; rep from * to last 4 sts, 1 ch, miss 1 st, 3 tr. Turn.

Row 3: 3 ch, 1 tr, *1 ch, miss 1 st, 1 tr into 1ch-sp, 1 ch, miss 1 st, 3 tr; rep from * to end omitting last tr on last rep. Turn.

Row 4: 4 ch (counts as 1 tr, 1 ch), miss next st, 1 tr into 1ch-sp, 1 tr, 1 tr into 1ch-sp, 1 ch, miss 1 st, 1 tr, *1 ch, miss 1 st, 1 tr into 1ch-sp, 1 tr, 1 tr into 1ch-sp, 1 ch, miss 1 st, 1 tr; rep from * to end. Turn.

Row 5: 3 ch, tr in each tr and 1ch-sp across to beg 4 ch, 1 tr in 4th ch, 1 tr in 3rd ch. Turn.

Rows 6-19 (20, 20, 21, 21) (22, 22, 23, 23): 3 ch, tr across. Turn.

We will now work short rows to create shoulder panels.

Count 21 (24, 30, 33, 36) (39, 42, 48, 51) sts from left edge, pm in this st. Rep from right edge.

Right Shoulder

Row 1 (WS): 3 ch, tr across to marked st, 1 tr in marked st, rm. Turn. 21 (24, 30, 33, 36) (39, 42, 48, 51) sts

Row 2: 3 ch, 1 tr 2tog, tr across. Turn. 20 (23, 29, 32, 35) (38, 41, 47, 50) sts

Schematic

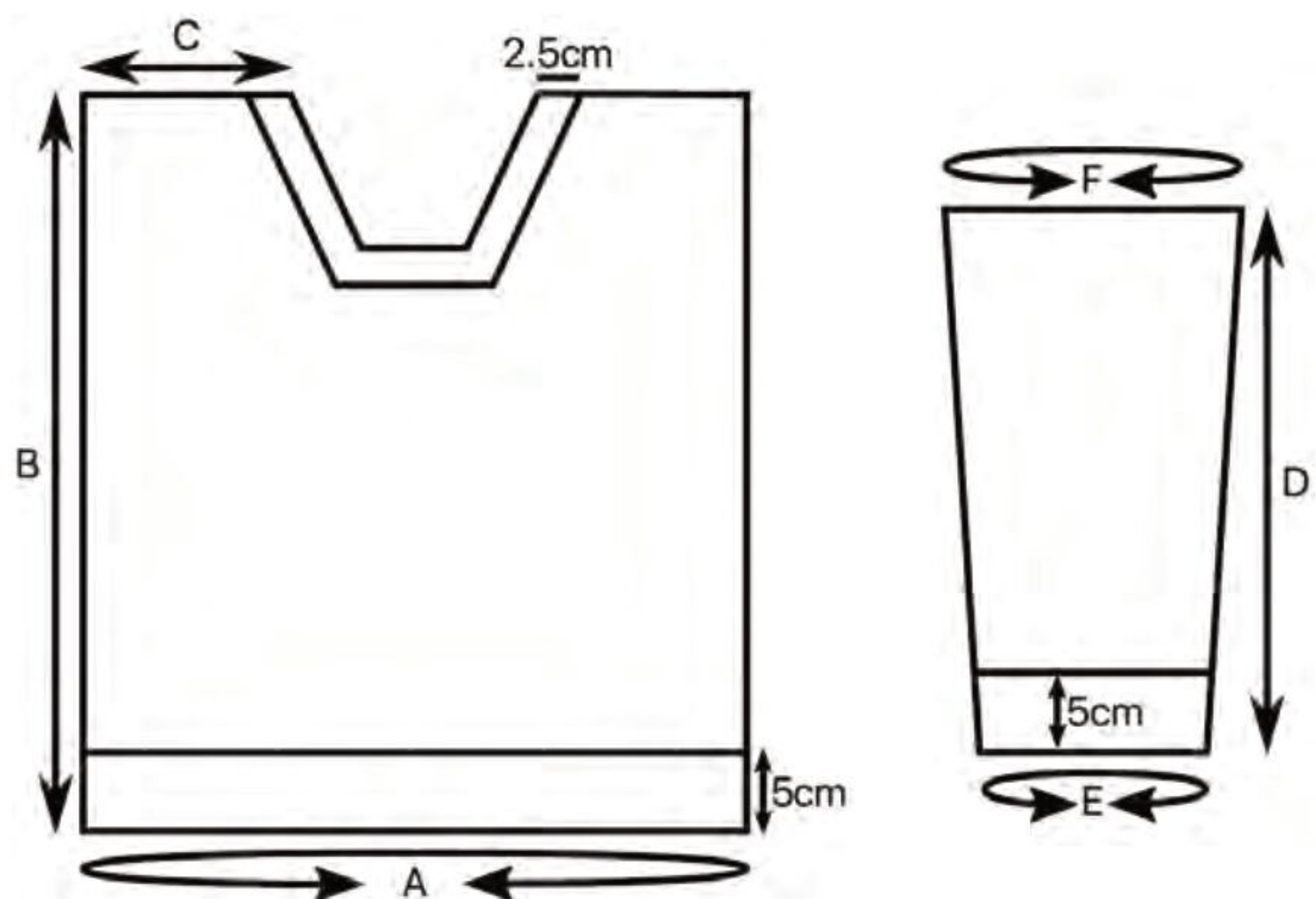



Row 3: 3 ch, tr across to last 3 sts, 1 tr2tog, 1 tr. Turn. 19 (22, 28, 31, 34) (37, 40, 46, 49) sts

Row 4: As Row 2. 18 (21, 27, 30, 33) (36, 39, 45, 48) sts

Row 5: As Row 3. 17 (20, 26, 29, 32) (35, 38, 44, 47) sts

Row 6: As Row 2. 16 (19, 25, 28, 31) (34, 37, 43, 46) sts

Row 7: As Row 3. 15 (18, 24, 27, 30) (33, 36, 42, 45) sts

Row 8: As Row 2. 14 (17, 23, 26, 29) (32, 35, 41, 44) sts

Fasten off, leave a long tail for seaming.

Left Shoulder

Row 1: With WS facing, join yarns with sl st in marked st, rm, 3 ch, tr across. Turn. 21 (24, 30, 33, 36) (39, 42, 48, 51) sts

Row 2: 3 ch, tr across to last 3 sts, 1 tr2tog, 1 tr. Turn. 20 (23, 29, 32, 35) (38, 41, 47, 50) sts

Row 3: 3 ch, 1 tr2tog, tr across. Turn. 19 (22, 28, 31, 34) (37, 40, 46, 49) sts

Row 4: As Row 2. 18 (21, 27, 30, 33) (36, 39, 45, 48) sts

Row 5: As Row 3. 17 (20, 26, 29, 32) (35, 38, 44, 47) sts

Row 6: As Row 2. 16 (19, 25, 28, 31) (34, 37, 43, 46) sts

Row 7: As Row 3. 15 (18, 24, 27, 30) (33, 36, 42, 45) sts

Row 8: As Row 2. 14 (17, 23, 26, 29) (32, 35, 41, 44) sts

Fasten off, leave a long tail for seaming.

Sleeve (make 2)

Holding one strand of each yarn tog, chain 39 (39, 45, 51, 51) (57, 57, 63, 69).

Row 1 (RS): Starting in 4th ch from hook, tr in back bump across. Turn. 37 (37, 43, 49, 49) (55, 55, 61, 67) sts

Rows 2-5: As rows 2-5 of Body.

Rows 6-9: Rep rows 2-5.

Row 10: 3 ch, 1 tr in first st, tr across to last st, 2 tr in last st. Turn. 39 (39, 45, 51, 51) (57, 57, 63, 69) sts

Row 11: As Row 10. 41 (41, 47, 53, 53) (59, 59, 65, 71) sts

Row 12: 3 ch, tr across. Turn.

Rows 13-18: Rep rows 10-12 twice. 49 (49, 55, 61, 61) (67, 67, 73, 79) sts

Next 1 (1, 1, 2, 2) (3, 3, 4, 4) row(s): 3 ch, tr across. Turn.

Fasten off, leave a long tail for seaming.

Finishing

Block each panel according to given measurements.

Using st markers, pin RS of Body panels tog. Using whip stitch, seam from bottom corner upwards, leaving 12 (13, 14, 15, 15) (16, 17, 18, 19) rows from top edge unseamed for armhole. Rep on other side.

Fold sleeve panel with RS tog. Using whip stitch, seam Sleeve into a tube.

Pin sleeve to armhole. Using whip stitch, seam Sleeve to Body panels. Rep for other Sleeve.

Turn jumper the right way around so the RS is facing out. Using mattress stitch, seam shoulder sts. Rep for other shoulder.

Neckline

With RS facing, join both yarns held tog with sl st in first unworked st of Row 19 (20, 20, 21, 21) (22, 22, 23, 23) on the back panel, chain 6.

Row 1: Starting in 2nd ch from hook, sl st in the back bump across ch, [sl st in next st on Body] twice. Turn. 7 sts

Row 2: Miss 2 sl sts, sl st in BLO across. 5 sts

Row 3: 1 ch, sl st in BLO across, [sl st in next st on Body] twice. 7 sts

Rep rows 2 and 3 around neckline. Fasten off. Using mattress stitch, seam first and last rows of ribbing tog.

Waistband

Join both yarns held tog with sl st in st after either seam at bottom edge of jumper, chain 11.

Row 1: As Row 1 of Neckline Ribbing. 12 sts

Row 2: Miss 2 sl sts, sl st in BLO across. 10 sts

Row 3: 1 ch, sl st in BLO across, [sl st in next st on Body] twice. 12 sts

Rep rows 2 and 3 around waist. Fasten off. Using mattress stitch, seam first and last rows of ribbing tog.

Sleeve Cuff

Joining in st after seam and working joining sl sts into Sleeve, rep Waistband ribbing around end of each Sleeve.

Weave in ends. 



Chunky Monkey

Add a little mischief to your yarn choice! This cheeky aran-weight version of our popular Colour Crafter yarn brings the new advantage of anti pilling. In 93 shades that perfectly co-ordinate with our popular Colour Crafter yarn collection, Chunky Monkey offers more choice for crafters who wish to use an affordable, easy care, lightweight and hypoallergenic yarn that maintains its quality despite lots of use.

Its thicker weight makes it super cosy and perfect for creating large and fast to work up items such as blankets, homeware and children's toys. Chunky Monkey is available in a broad colour palette covering all the colours of the rainbow!

Yarn 12: Romance

In this issue, revel in the undying love for nature, the female form and minute detail shared by the artists and influencers of the Pre-Raphaelite and Arts and Crafts movements of the 19th century, with our 12th issue of *YARN Bookazine*.

This issue features 17 modern crochet and knitting patterns reminiscent of this incredible era of art, fusing the functional with the beautiful through a range of stitch techniques, fibres, embroidered details and colour palettes. The stunning lacework stitch patterns and traditional motifs inspired by paintings, wallpapers and tapestries echo Victorian style; highly embellished items for the home and wearable accessories are a celebration of crafts and the joy of making.

The theme of 'romance' is further explored in interviews with artists and bloggers who have also been inspired by the ideals and aesthetics of these influential art movements. In-depth features delve into the lives of the people and the history that infuses this issue.

Scheepjes® Yarn FOCUS



Matt Farci

This month, Scheepjes's Matt Farci shows us his favourite yarns on the market



Yarn The After Party 127 – Rainbow Dots blanket

Bring warmth and joy into your home with the Rainbow Dots Blanket designed by Jellina Verhoeff and made with cosy 75% extra-fine Merino, Scheepjes Metropolis. All 80 shades from the Metropolis Colour Pack contribute to the vibrant colour palette, wonderfully enhanced by a neutral ecru frame. Blocks of airy filet crochet are made individually, making this a perfectly portable project to pop in a bag. Repeated squares are then joined in neat rows to create the clean graphic look of this modern, feel-good blanket.



Special stitches

Raised double treble Front

(RdtrF): Work the dtr around the post of the st inserting hook from front to back around to front again



Jane Howarth

Twilight Tones BLANKET

Slip into sweet dreams under this beautiful two-toned blanket

 Aran  5mm

★★ Intermediate

Yarn used

Caron Simply Soft
3 balls in Victorian Rose 9721 (MC)
6 balls in Off White 9702 (CC)
Available from
www.woolwarehouse.co.uk

About the yarn

Aran; 288m per 170g ball; 100% acrylic

Tension

13 sts x 11 rows = 10cm measured over patt

Hook used

5mm

Sizing

129x112cm

This is an all-in-one project with minimal making up required.

With a repeat of two sets of cables over four rows, you can find your place fairly easily – but the rows are long, so check your work regularly.

Start crocheting...

Once patt is set, RdtrF are worked into RdtrF sts of the previous RS (odd-numbered) row.

Cable sets alternate between diagonal and vertical. Diagonal RdtrF sts are always worked into vertical RdtrF sts, while vertical RdtrF sts are always worked into diagonal RdtrF sts.

Beg 3 ch counts as tr throughout.

With MC, chain 158.

Row 1: Starting in 2nd ch from hook, dc across. Turn. 157 sts

Row 2: 1 ch, dc across. Turn.

Row 3: 3 ch, tr across. Turn.

Row 4: 3 ch, tr across. Turn.

Row 5: 1 ch, 2 dc, [1 RdtrF around tr 2 rows below, 1 dc] twice, *miss 3 sts, 2 RdtrF, 1 dc in 3rd of 3 missed sts, 2 RdtrF starting in first of 3 missed sts, 1 dc, [1 RdtrF around tr 2 rows below, 1 dc] twice; rep from * 14 times more, 1 dc. Turn.

Row 6: As Row 4.

Row 7: 1 ch, 2 dc, miss 2 sts, 1 RdtrF around next st, 1 dc in 2nd missed st, 1 RdtrF around first of 2 missed sts, 1 dc, *[2 RdtrF, 1 dc] twice, miss 2 sts, 1 RdtrF around next st, 1 dc in 2nd missed st, 1 RdtrF around first of 2 missed sts, 1 dc; rep from * 14 times more, 1 dc. Turn.

Row 8: As Row 4.

Row 9: 1 ch, 2 dc, [1 RdtrF, 1 dc] twice, *miss 3 sts, 2 RdtrF, 1 dc in 3rd of

3 missed sts, 2 RdtrF starting in first of 3 missed sts, 1 dc, [1 RdtrF, 1 dc] twice; rep from * 14 times more, 1 dc. Turn.

Rep rows 6-9 ten times more. Fasten off MC. With CC, rep rows 6-9 eighteen times more Rep Row 2 twice.

Fasten off. Weave in ends.

Block to dimensions. 



Chart

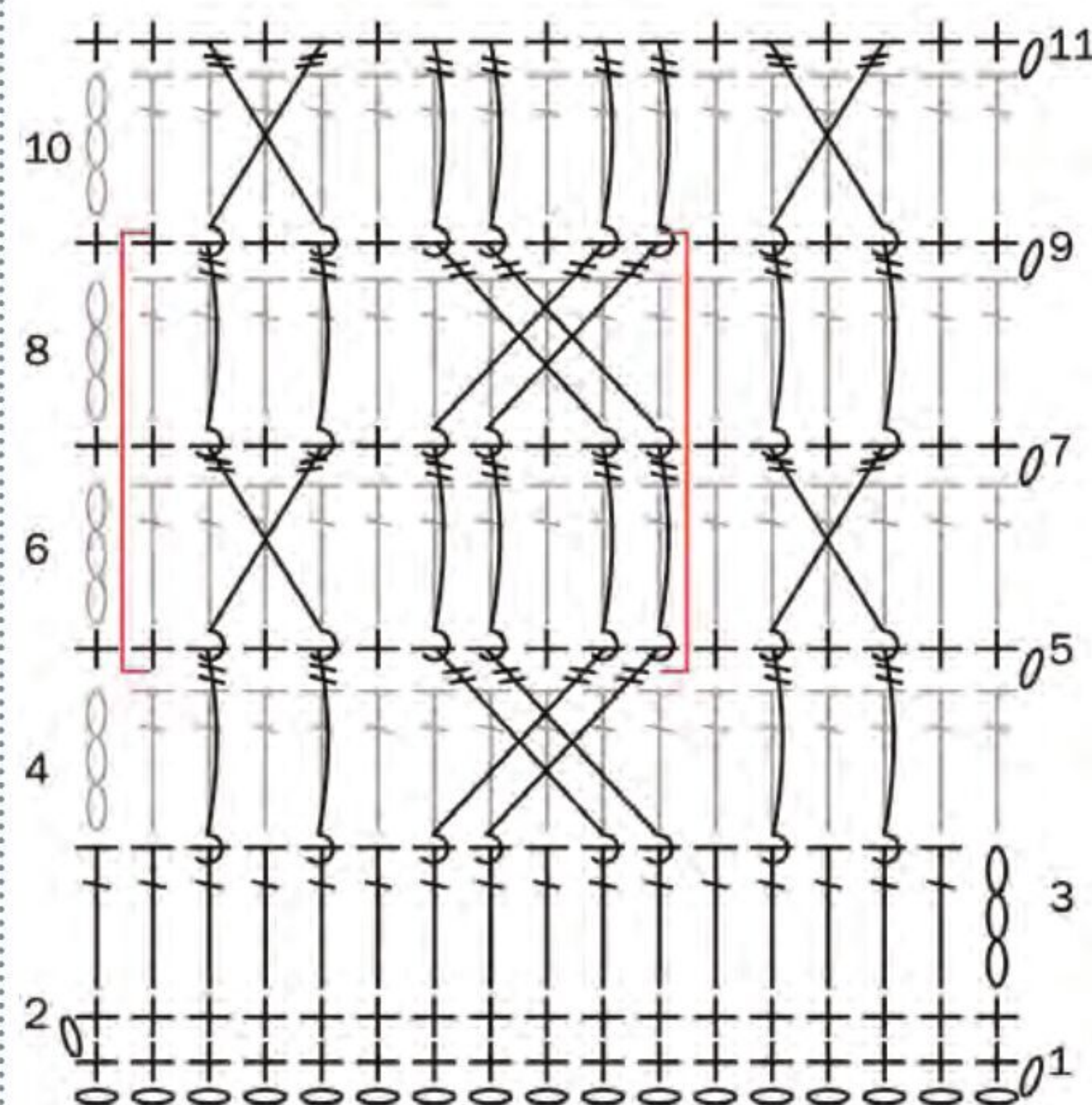

Key

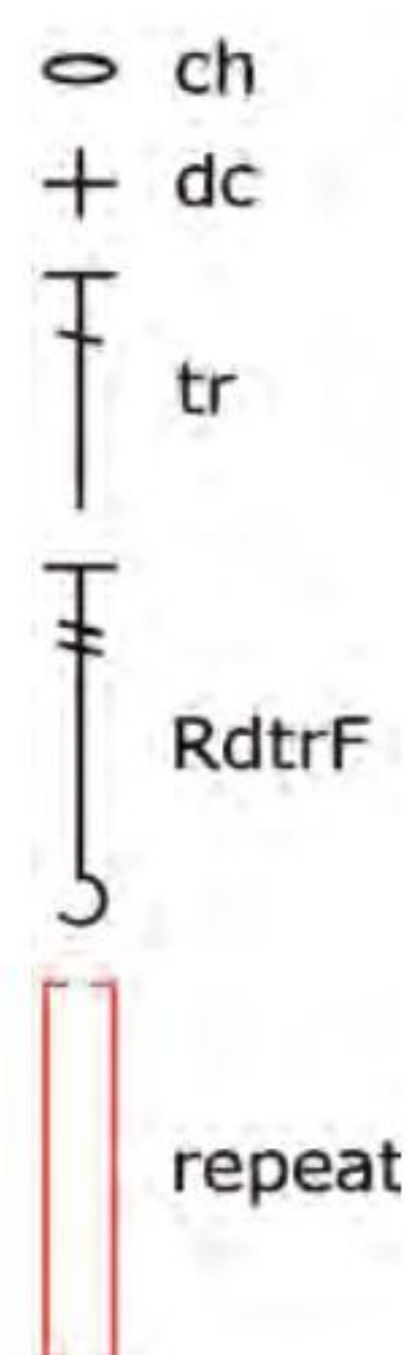



Jane Howarth

DK 4mm

★★ Try something new

Yarn used

Romade Yarns BFL DK
 2 balls in Gloriously Grey (MC)
 1 ball in Naturally Neutral (CC)
 Available from www.woolfull.com

About the yarn

DK; 225m per 100g ball; 100% British Bluefaced Leicester

Tension

11.5 rows x 18 sts = 10cm measured over patt

Hook used

4mm

Sizing

128x26.5cm

Chart

Key

- ch
- × dc
- ∧ dc2tog
- ⌈ htr
- ⌈ tr
- ⌈ dtr
- × CC
- × MC

COMFY CHIC WRAP

Keep yourself warm and spruce up your 2022 wardrobe with this beautiful wrap

The wrap is worked as two panels to allow the cloud-like movement to flow evenly to the centre.

Start crocheting...

Shells are worked into the next dc throughout. With the exception of the CC border, all dc are worked into the first tr of shell (RS) or 2nd tr of shell (WS) throughout; dtr sts are always missed.

Panels (make 2)

With CC, chain 10.

Row 1 (RS): Starting in 2nd ch from hook, 1 dc, miss 2 chs, 1 shellRS, miss 2 chs, 1 dc, miss 2 chs, [1 dtr, 2 tr] in last ch. Turn. *9 sts*

Row 2: 1 ch (does not count as a st here and throughout), 2 dc, 1 shellWS in next dc, change to MC, 1 dc in 3rd st of next shell, 1 shellWS in last dc. Turn. *11 sts*

Row 3: 4 ch (counts as a st), [2 tr, 1 htr] in 3rd ch from hook, miss first st, 1 dc, change to CC, 1 shellRS, miss 1 st, 1 dc, miss 2 sts, [1 dtr, 2 tr] in next dc, 1 tr. Turn. *14 sts*

Note: Work the final dc2tog of Row 4 and all following WS rows over the last 2 sts of the Row.

Row 4: 1 ch, 3 dc, 1 shellWS, 1 dc, 1 shellWS, change to MC, 1 dc2tog over last 2 sts. Turn. *13 sts*

Row 5: 3 ch (counts as a st here and throughout), [2 tr, 1 htr] in first st, miss 1 st, 1 dc, change to CC, [1 shellRS, miss 1 st, 1 dc] twice. Turn. *15 sts*

Row 6: 3 ch, [1 tr, 1 dtr] in first st, miss 2 sts, 1 dc, 1 shellWS, change to MC, 1 dc, 1 shellWS, 1 dc2tog. Turn. *14 sts*

Row 7: 3 ch, [2 tr, 1 htr] in first st, miss 1 st, 1 dc, 1 shellRS, change to CC, 1 dc, 1 shellRS, miss 1 st, 2 dc. Turn. *16 sts*

Row 8: 3 ch, [2 tr, 1 dtr] in next st, 1 dc, 1 shellWS, change to MC, 1 dc, 1 shellWS, 1 dc2tog. *15 sts*

Row 9: 3 ch, [2 tr, 1 htr] in first st, miss 1

st, 1 dc, change to CC, 1 shellRS, 1 dc, 1 shellRS, miss 1 st, 3 dc. *17 sts*

Row 10: 1 ch, 1 dc in first st, miss 1 st, 1 shellWS, 1 dc, 1 shellWS, 1 dc, change to MC, 1 shellWS, 1 dc2tog. *16 sts*

Row 11: 3 ch, [2 tr, 1 htr] in first st, miss 1 st, 1 dc, 1 shellRS, change to CC, 1 dc, 1 shellRS, 1 dc, miss 2 sts, [1 dtr, 2 tr] in last st. Turn. *18 sts*

Row 12: 1 ch, 2 dc, 1 shellWS, 1 dc, change to MC, 1 shellWS, 1 dc, 1 shellWS, 1 dc2tog. Turn. *17 sts*

Row 13: 3 ch, [2 tr, 1 htr] in first st, miss 1 st, 1 dc, 1 shellRS, 1 dc, change to CC, 1 shellRS, 1 dc, miss 2 sts, [1 dtr, 2 tr] in next st, 1 tr. Turn. *19 sts*

Row 14: 1 ch, 3 dc, 1 shellWS, 1 dc, 1 shellWS, change to MC, 1 dc, 1 shellWS, 1 dc2tog. Turn. *18 sts*

Row 15: 3 ch, [2 tr, 1 htr] in first st, miss 1 st, 1 dc, 1 shellRS, 1 dc, change to CC [1 shellRS, 1 dc] twice, working last dc in last st. Turn. *20 sts*

Row 16: 3 ch, [1 tr, 1 dtr] in first st, miss 2 sts, 1 dc, 1 shellWS, change to MC, [1 dc, 1 shellWS] twice, 1 dc2tog. Turn. *19 sts*

Row 17: 3 ch, [2 tr, 1 htr] in first st, miss 1 st, [1 dc, 1 shellRS] twice, change to CC, 1 dc, 1 shellRS, miss 1 st, 2 dc. Turn. *21 sts*

Row 18: 3 ch, [2 tr, 1 dtr] in next st, miss 2 sts, 1 dc, 1 shellWS, change to MC, [1 dc, 1 shellWS] twice, 1 dc2tog. *20 sts*

Row 19: 3 ch, [2 tr, 1 htr] in first st, miss 1 st, 1 dc, 1 shellRS, 1 dc, change to CC, [1 shellRS, 1 dc] twice, 2 dc. *22 sts*

Row 20: 1 ch, 1 dc in first st, miss 1 st, 1 shellWS, 1 dc, 1 shellWS, 1 dc, change to MC, 1 shellWS, 1 dc, 1 shellWS, 1 dc2tog. *21 sts*

Row 21: 3 ch, [2 tr, 1 htr] in first st, miss 1 st, [1 dc, 1 shellRS] twice, change to CC, 1 dc, 1 shellRS, 1 dc, miss 2 sts, [1 dtr, 2 tr] in last st. Turn. *23 sts*

Row 22: 1 ch, 2 dc, 1 shellWS, 1 dc, change to MC, 1 shellWS, [1 dc, 1 shellWS] twice, 1 dc2tog. Turn. *22 sts*



Row 23: 3 ch, [2 tr, 1 htr] in first st, miss 1 st, [1 dc, 1 shellRS] twice, 1 dc, change to CC, 1 shellRS, 1 dc, miss 2 sts, [1 dtr, 2 tr] in next st, 1 tr. Turn. *24 sts*

Row 24: 1 ch, 3 dc, 1 shellWS, 1 dc, 1 shellWS, change to MC, [1 dc, 1 shellWS] twice, 1 dc2tog. Turn. *23 sts*

Rows 25-74: Rep rows 15-24 five times more, working one more shell and dc in MC with each rep, as MC edge increase allows; keep number of CC sts as written to end.

On WS rows: Work an additional shellWS rep in patt until working last dc2tog.

On RS rows: Work MC shell reps in patt up to colour change as directed.

Fasten off. Do not fasten off on 2nd panel.

Making up

Place panels RS tog with Row 74 of both panels tog and sts aligned. Cont with MC and working through both layers, 36 dc to colour change, change to CC, dc to end. *48 sts* Alternatively, sew up for an invisible seam. Fasten off. Weave in ends.

Block to dimensions. 🧶

Special stitches

Asymmetrical shell on Right Side

(shellRS): [1 dtr, 2 tr, 1 htr] in next dc

Asymmetrical shell on Wrong Side

(shellWS): [1 htr, 2 tr, 1 dtr] in next dc

Take care over colour changes for a neat finish. For best results, leave the unused strand loose as you change colours – as you approach it on the following row, work over the loose strand on the final st in the alternate colour. Draw strand up to complete last loop of st, and cont in patt

**TO READ THE
FULL INTERVIEW,
VISIT [WWW.
CRAFTWORLD.COM](http://WWW.CRAFTWORLD.COM)**



Reprinted with permission from Modern Crochet Sweaters by Janine Myska, Page Street Publishing, Co. 2021. Photo credit: Stephanie Lauren.

JANINE MYSKA

We are so excited for Janine Myska's new book, *Modern Crochet Sweaters*, and were lucky enough to get an exclusive interview with Janine herself!

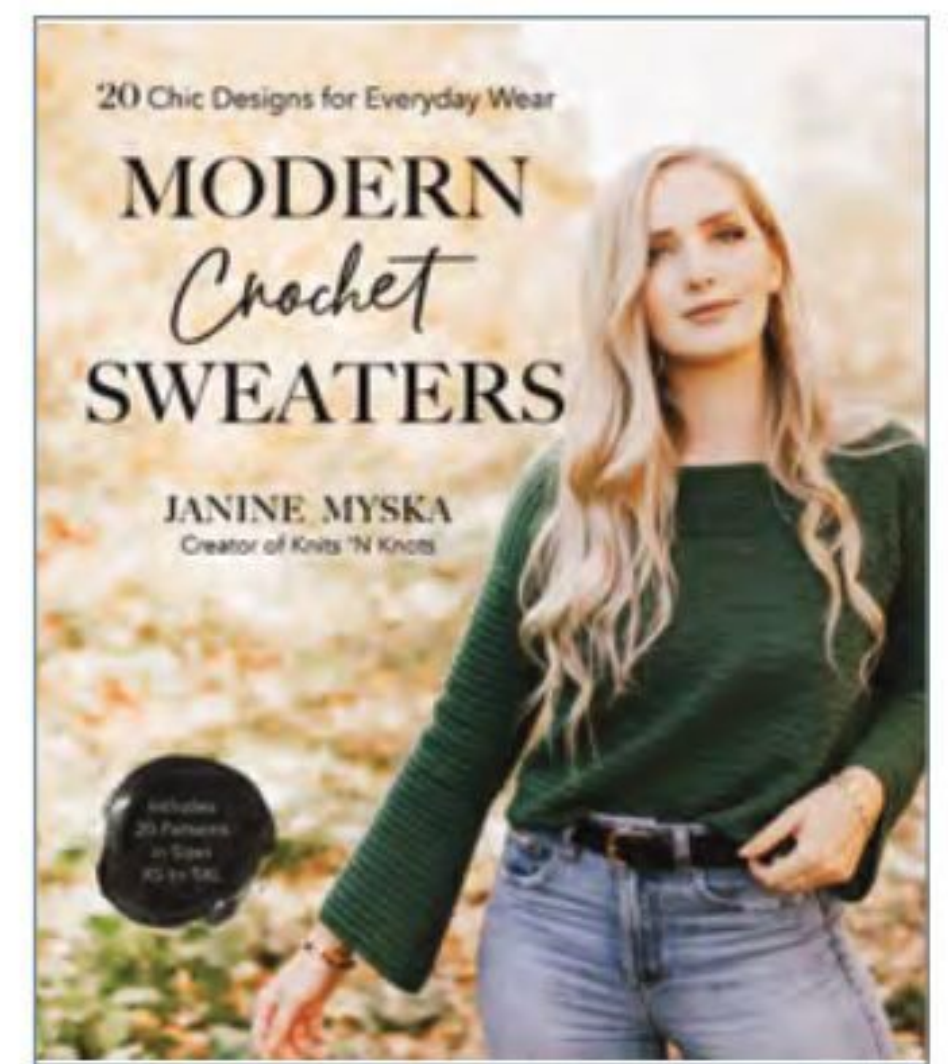

Modern Crochet Sweaters
By Janine Myska
£17.99, Page Street Publishing

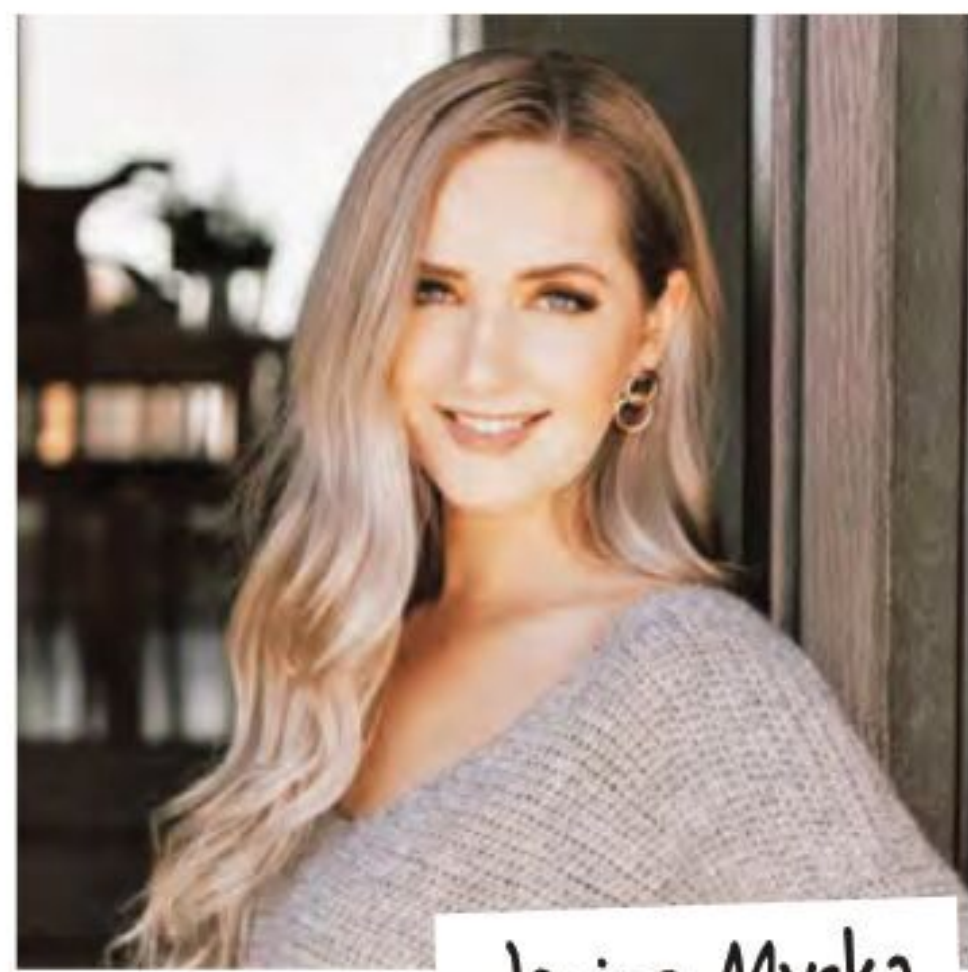

Janine Myska

Hi Janine, thanks for speaking with us! Please tell us a little about you and your everyday life

I live in Winnipeg, Canada, with my partner Matt and our two dogs, Pancake and Joe. We bought our first house in 2020 and have been slowly renovating it together on the weekends! It is my absolute dream to be able to work from home every day, writing patterns and creating all kinds of knitting and crochet content for a living. I create and release patterns independently and work with yarn companies to develop patterns for new yarn lines.

Congratulations on your new book, *Modern Crochet Sweaters*! Tell us about how you came to write this book

Thank you! After the concept of a potential book was introduced to me, I knew right away that it should be a crochet sweater book. They are my favourite things to make and design and have always been the most popular category with my audience. I think that much of the growth of my business over the last few years can be attributed to writing patterns with inclusive sizing from XS-5X, which was not very common among pattern designers at the time. I knew the book had to be size-inclusive as well. For many of these patterns, I asked my audience on Instagram to design the sweaters with me through polls and questionnaires asking for their input. It was a fun way to come up with new sweater patterns together!

What was your aim when bringing this fabulous collection together?

My goal in writing this book was to bring forward a size-inclusive collection of wearable crochet patterns with a store-bought look that can be incorporated into an everyday wardrobe. Beautifully fitting sweaters are for everybody, and each pattern was thoughtfully graded to suit a range of bodies, from a 28-62" bust. You'll find customisation tips within each pattern to help you achieve the best possible fit for your unique body measurements. No size is an afterthought; I want you to feel as though this book was written just for you. There is an accompanying blog post for each design in the book which lists yarn substitutions, customisation ideas, and showcases all the tester photos so you can see how the sweater looks on a range of bodies. I had over 500 pattern testers for this book to make sure that each size fits its intended wearer in a way that makes them feel beautiful!

Which project is your favourite in the collection, and why?

My favourite project in the book changes depending on the day, but right now I'm really loving the clean and sophisticated look of the Lakeside Mist cardigan. This piece features a unique sideways construction, a pretty texture, and statement ribbing around the collar, sleeve cuffs, and bottom hem that really brings this simple design to the next level. This is one of the most versatile pieces in the book, with a lot of customisation options within the pattern. This pattern (along with each pattern in the book) is also available independently on my website (www.knitsnknots.ca) and most pattern-selling platforms.

What makes crochet and designing crochet garments special for you?

With crochet specifically, I love the freedom of stitch placement. Since there is only one live stitch at any given moment, you are free

to place new stitches wherever you like. You can make decisions on the fly, whereas knitting requires a little more planning since you are working with so many live stitches. When I'm writing a garment pattern, I recognise that everybody has certain styles or certain elements of clothing that they feel more comfortable in (sweater length, sleeve length, neckline depth, etc), so I like to incorporate tips and tricks throughout the pattern on how to adjust most of these elements to ensure the crocheter can make modifications if they so choose. That is the empowering thing about crocheting your own clothes – you can make something that fits your body perfectly.



Are you working on anything else exciting at the moment you want to tell our readers about?

2022 will be filled with so many brand-new patterns, but I've also got a hand-dyed yarn collection that releases in the spring with a few accompanying patterns! I converted part of my basement into a dye studio early last year and have been slowly preparing for this yarn launch, so stay tuned for that!



Turn over to crochet Janine's beautiful poncho!

Get to know
Janine on Instagram
knitsnknotswpg

 **Chunky**  **5.5mm**

★ **Beginner friendly**

Yarn used

Lion Brand Hue and Me
11 (12, 14, 15) balls in Desert
617-099

Available from www.lionbrand.com

About the yarn

Chunky; 125m per 125g ball; 80% acrylic,
20% wool

Tension

9 sts x 6 rows = 10cm measured
over tr
12 sts x 11 rows = 10cm measured
over dc in BLO (unstretched)

Hook used

5.5mm

Other supplies

tapestry needle
stitch markers

Sizing

XS (S/M/L, XL/2X/3X, 4X/5X)
Designed to be worn with 20-64cm
positive ease, if between sizes,
size down
A: 124 (142, 160, 178) cm
B: 74cm
C (unfolded): 15.5cm

Note that when working PS, you will find it helpful to pull your loops up a little bit to make it easier to pull through all the loops on your hook.

Make sure you check your tension for the Turtleneck as well. Use whatever hook allows you to achieve the turtleneck tension, or your desired fit for the turtleneck. You might match tension with the same hook, or you might need to use a different hook to achieve the proper tension for this ribbed turtleneck.

For a shorter (or taller) turtleneck than the sample shown, work fewer (or additional) chains as you see fit.

INFINITE PRAIRIES PONCHO

The prairies have a beauty that is subtle and understated, much like this design. Slip your Infinite Prairies poncho over any outfit for a laid-back, comfortable look this winter

Reprinted with permission from Modern Crochet Sweaters by Janine Myska, Page Street Publishing, Co. 2021. Photo credit: Stephanie Lauren.

This poncho has a circular yoke construction, worked from the top down. To make the Infinite Prairies poncho, you begin with the turtleneck, and then work the puff stitch pattern in joined rounds, increasing every few rounds until reaching the depth at which you will place the armholes. Next, two separate sections are worked to create space for the arms, and then re-joined to work in rounds until your desired length.

Beg 2 ch does not count as a st.

☀ Start crocheting...

Turtleneck

Chain 21, leaving a 30cm tail for seaming the turtleneck.

Row 1: Starting in 2nd ch from hook, dc across. Turn. *20 sts*

Row 2: 1 ch, dc in BLO across. Turn. Rep Row 2 until you have a total of 56 rows completed.

Rotate your work to begin working across the row ends.

Joining Rnd: 1 ch, work 1 dc into the ends of each row of ribbing, then bring your first and last st tog to form a tube, join with sl st to beg dc. Turn. *56 dc*

With tapestry needle and beg tail, seam turtleneck closed using the whip stitch or seaming method of your choice.

Body

Rnd 1: 2 ch, 1 (2, 3, 3) tr, [1 PS, 2 ch, 1 PS] in next st, {6 tr, [1 PS, 2 ch, 1 PS] in next st} 7 times, 5 (4, 3, 3) tr, join with sl st to beg tr. Turn. *48 tr, 16 PS*

Rnd 2 (Increase Rnd): 2 ch, {tr across to next PS, 1 tr in next PS, [1 PS, 2 ch, 1 PS] into 2ch-sp, 1 tr in next PS} 8 times, tr to end of rnd, join with sl st to beg tr. Turn. *64 tr, 16 PS*

Rnd 3: 2 ch, {tr across to next PS, miss PS, [1 PS, 2 ch, 1 PS] into 2ch-sp, miss next PS} 8 times, tr to end of rnd, join with sl st to beg tr. Turn.

Rep rnds 2-3 two (three, four, five) times more. *96 (112, 128, 144) tr, 16 PS*

There is now a total of 7 (9, 11, 13) rnds and 12 (14, 16, 18) tr in between each PS.

Rep Rnd 3 seven (five, four, two) times more.

There is now a total of 14 (14, 15, 15) rnds completed.

Split for Sleeve Opening

Section 1

To create sleeve openings without interrupting the st patt, you will work two sections in back and forth rows, creating two armhole openings, and then connect them again to close up the armholes.

ALL SIZES:

Row 15 (15, 16, 16): 2 ch, tr across to first PS, miss PS, [1 PS, 2 ch, 1 PS] into 2ch-sp, miss next PS, {tr across to next PS, miss PS, [1 PS, 2 ch, 1 PS] into 2ch-sp, miss next PS} 5 times, 4 (6, 8, 9) tr, leave rem sts unworked, pm in next st (you will return to this in Section 2). Turn. *68 (82, 96, 108) tr, 12 PS*

Rows 16 (16, 17, 17)–27: 2 ch, tr across to first PS, miss PS, [1 PS, 2 ch, 1 PS] into 2ch-sp, miss next PS, {tr across to next PS, miss PS, [1 PS, 2 ch, 1 PS] into 2ch-sp, miss next PS} 5 times, tr to end of row. Turn.

Pull up this live loop and put a st marker in it to hold it in place. You will come back to it after completing Section 2. When you return to this live loop, you will continue working in the same direction as Row 27, working over Section 2.

Section 2

To create Section 2, lay your work out flat with the unworked section of Row 15 facing you. You are going to join yarn in marked st (the 2nd available st from the RH side), leaving 1 st unworked after the first completed section.

Row 15 (15, 16, 16): With new ball, join with sl st in 2nd st from the first section, leaving 1 st unworked between Sections 1 and 2, 2 ch, *tr across to next PS, miss PS, [1 PS, 2 ch, 1 PS] into 2ch-sp, miss next PS; rep from * once more, tr across to last st, miss last st to have 1 st unworked between Section 1 and Section 2. Turn. *26 (28, 30, 34) tr, 4 PS*

Rows 16 (16, 17, 17)–26: 2 ch, *tr across to first PS, miss PS, [1 PS, 2 ch, 1 PS] into 2ch-sp, miss next PS; rep from * once more, tr to end of row. Turn.

Fasten off.

Insert hook into st on hold from Section 1. At this point, you have worked Row 27

over Section 1, but have not yet worked Row 27 over Section 2. Now you are going to cont Row 27, working over Section 2.

Row 27: 1 ch, 1 tr in first tr in Section 2, *tr across to next PS, miss PS, [1 PS, 2 ch, 1 PS] into 2ch-sp, miss next PS; rep from * once more, tr to end of row, 1 ch, join with sl st to beg tr from Row 27-Section 1. Turn.

Rnd 28: Rep Rnd 3, working 1 tr into each 1ch-sp. *96 (112, 128, 144) tr, 16 PS*

Rnds 29-44: Rep Rnd 3.

For a shorter (or longer) poncho, work fewer (or additional) reps of Row 3 until reaching your desired length.

Fasten off.

Finishing Armhole Openings

Rnd 1: Join with sl st to bottom of armhole opening, 1 ch, dc evenly around armhole opening, working approximately 2 dc in each row end, join with sl st to beg dc. Fasten off.

Rep for 2nd armhole. Weave in ends. ☀

Schematic

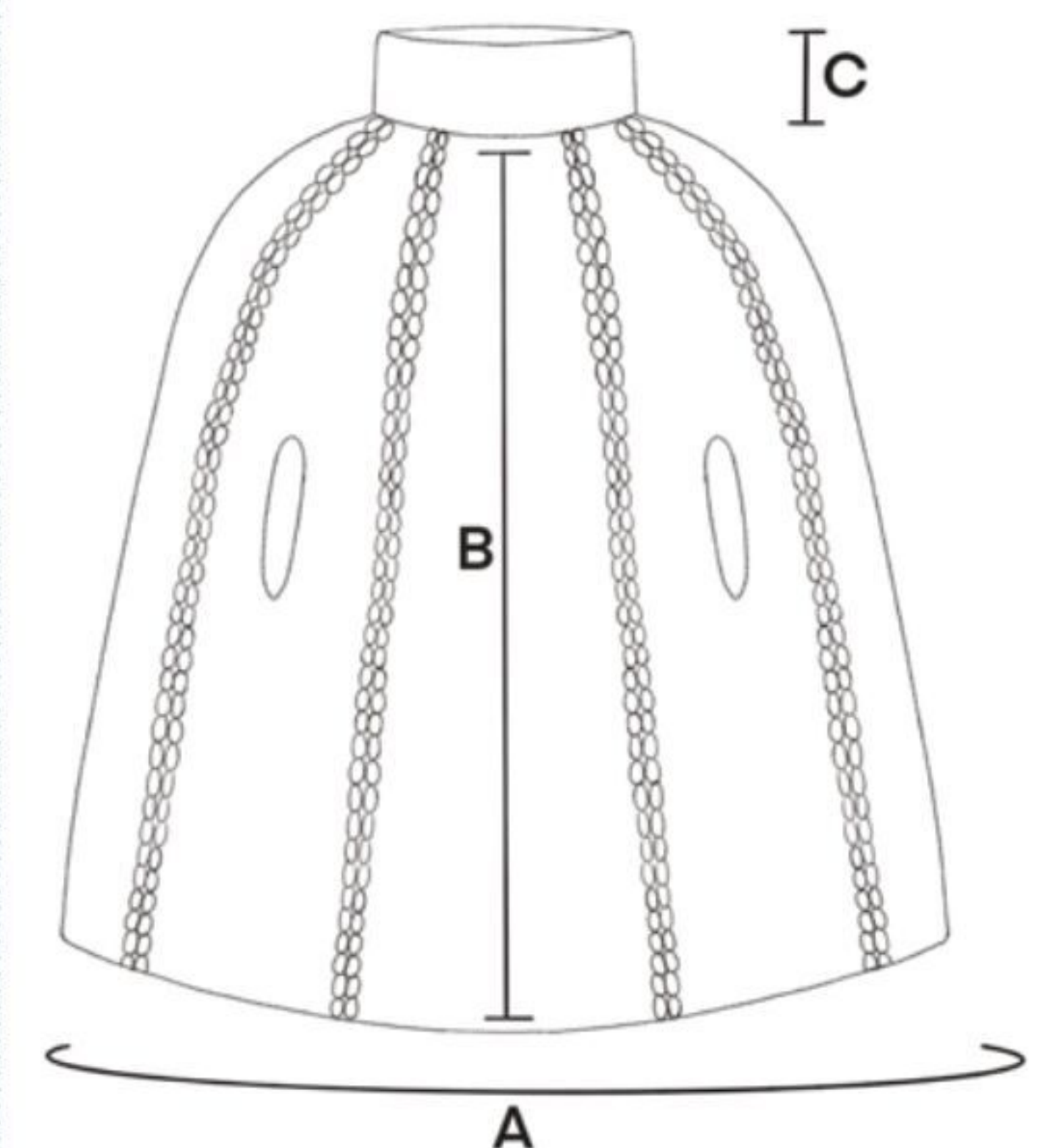

Special stitches

Puff stitch (PS): [Yrh, insert hook into indicated st, yrh, pul] 5 times into same st (11 loops on hook), yrh, draw through all 11 loops on hook



Bella Knit
YARN, FABRIC & HABERDASHERY



Great for all your knitting and crochet needs!

5 Balcony Parade, Corporation street, Corby, NN17 1NL
01536 267344
Facebook Bellaknit bellaknit@live.co.uk www.bellaknit.co.uk



ty.
EST 2011

SAVE 10%
USE
CN77

TANGLED YARN
www.tangled-yarn.co.uk
0161 217 0858

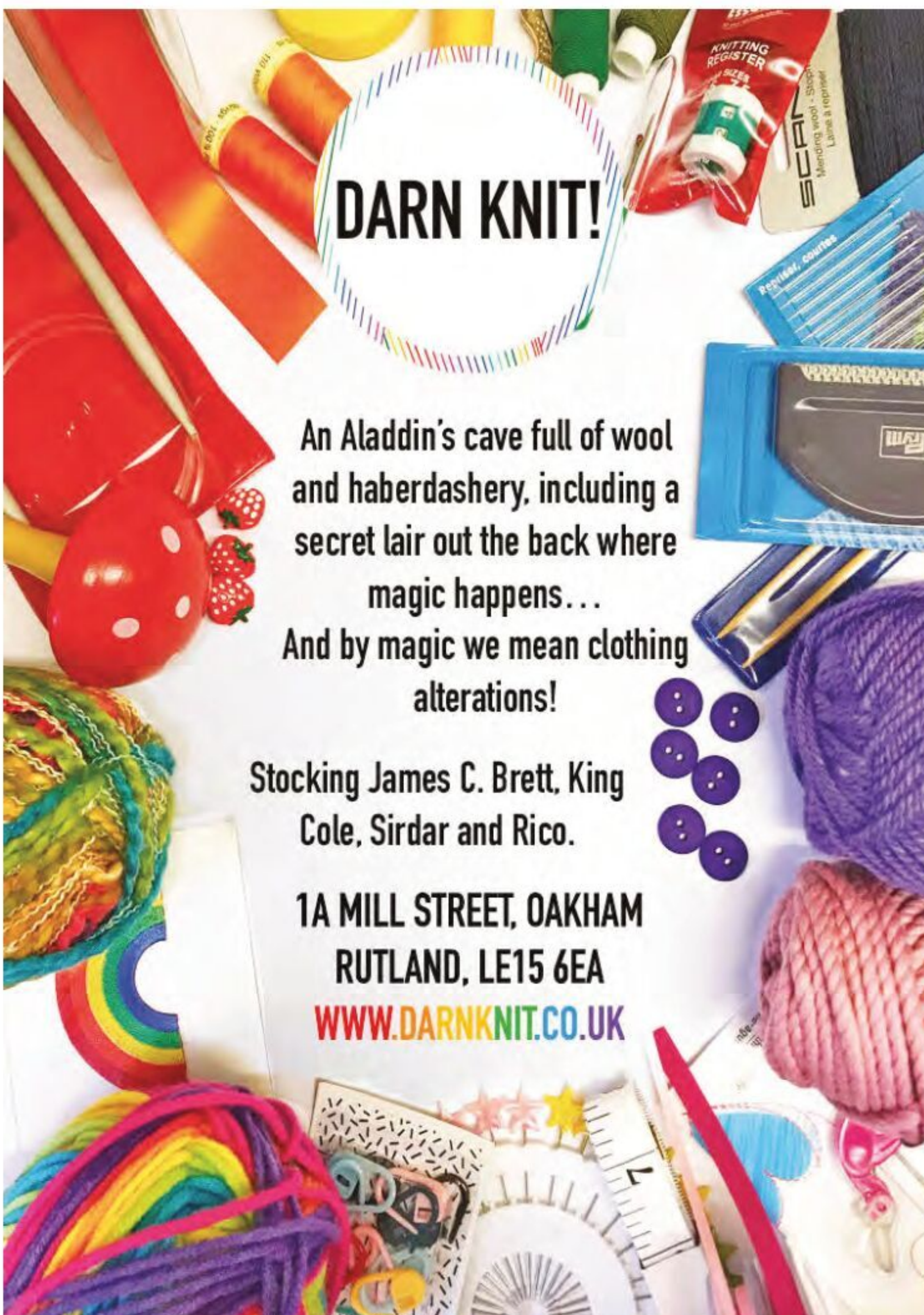

DARN KNIT!

An Aladdin's cave full of wool and haberdashery, including a secret lair out the back where magic happens...
And by magic we mean clothing alterations!

Stocking James C. Brett, King Cole, Sirdar and Rico.

1A MILL STREET, OAKHAM
RUTLAND, LE15 6EA
WWW.DARNKNIT.CO.UK

DesignaKnit 9 Comprises Standard Garment Styling, Original Pattern Drafting, Stitch Designer, Interactive Knitting, Graphics Studio

Choose your package:

- Handknit
- Standard
- Professional
- Complete

OUT NOW

- Trace a shape from a background image
- Outline, shading, curves, kaleidoscopic patterns
...and many more new features

Advanced tiling

Machine Lace now Included free

More detailed conversion of photos to stitch patterns

SEE WHAT'S NEW!
For purchases or upgrade info:
www.softbyte.co.uk
info@softbyte.co.uk
01691 828556

Soft Byte LTD



This year, TOFT is very proud to present the 'Making Women who Made History' project, a series of crocheted dolls celebrating inspirational women, at The Stitch Festival 2022.

“We celebrate the remarkable women who changed our world for the better”

In March 2020 TOFT introduced the first design, Emmeline Pankhurst, in celebration of International Women's Day. This year, TOFT is pleased to celebrate International Women's Day on March 8th with a showcase of these designs at the Stitch Festival.

With this ongoing crochet project, we celebrate the remarkable women who changed our world for the better. From artists, environmentalists and scientists to authors, aviators and activists, we travel through time exploring our rich history of talented and brave women. Once every four months, a new crochet pattern and yarn bundle is released to make the next inspirational female in this series. Using just basic crochet stitches and techniques, these



designs are easy for everyone to recreate.

Join TOFT to celebrate making inspirational women this year at The Stitch Festival as we reveal the next exciting woman in the series and fundraise for a cause close to our hearts. The latest design is of Junko Tabei, which will not be released until the spring, alongside lots of exciting new products to celebrate International Women's Day.

Japanese mountaineer, author and teacher Junko Tabei was the first woman to reach the summit of Mount Everest and the first woman to ascend the Seven Summits, climbing the highest peak on every continent. In addition to her climbing, Junko wrote seven books, worked on ecological projects and completed postgraduate studies focusing on 'clean-up' climbs in Japan and the Himalayas alongside her husband and children. In 2019 a mountain range on Pluto was named 'Tabei Montes' to honour her as a pioneer "who crossed new horizons in the exploration of

KERRY'S JOURNAL

This month, TOFT's Kerry Lord is excited to share how the team is celebrating inspirational women across the world

www.toftuk.com

the Earth, sea and sky".

The Stitch Festival is at the Business Design Centre from 3rd – 6th March 2022 and tickets can be booked at www.thestitchfestival.co.uk

#edsdollsclub



To read the full article, visit www.craftworld.com



WOOL WAREHOUSE

yarn

patterns & books

needles & hooks

£8.99
per 50g ball

Rowan Cotton Wool DK
60% Cotton, 40% Wool

£2.49
per 50g ball

James C Brett Dotti DK
50% Acrylic, 50% Cotton

£19.79
per 50g skein

King Cole KC Naturally Soft
4 Ply | 90% Wool, 10% Cashmere

£11.99
per 200g ball

Stylecraft Charm
85% Acrylic, 10% Wool, 5% Mohair

£3.49
per 100g ball

Sirdar Hayfield Soft Twist DK
90% Acrylic, 10% Merino Wool

£3.85
per 50g ball

Drops Soft Tweed DK
50% Wool, 25% Alpaca, 25% Viscose

£6.39
per 130g ball

Rico Creative Cotton Cord
100% Cotton

£7.95
per 50g ball

Rowan Norwegian Wool DK
100% Wool

Get a **FREE** pattern every Friday! Look out for updates on our Facebook page:
www.facebook.com/woolwarehouse

FREE UK DELIVERY
on orders over £25

Order online: www.woolwarehouse.co.uk

No minimum order. £2.95 delivery charge for UK orders under £25.

All the crochet supplies you'll ever need...all under one roof!

Get **10%** OFF EVERYTHING!
Discount code: **CN77**

Look At what I made SHOP



'Look At What I Made' Scheepjes yarn packs - make the Sophie's Dream Blanket and more!



£4.99
per 50g ball

Rico Essentials Super Aran
50% Acrylic, 50% Wool



£2.79
per 100g ball

Stylecraft Highland Heathers
DK
100% Acrylic



£4.99
per 25g ball

Anchor Artiste Metallic
80% Viscose, 20% Polyester

Attic24 SHOP



Yarn packs to make your own Attic24 projects, including the NEW Harbour Blanket CAL!



We're proud to stock all these leading brands

* Discount code not valid on yarn packs, sale items, Scheepjes, Lopi and King Cole KC products.



Zoë Potrac

WEATHERMAN JUMPER

Hook up one of these adorable jumpers
for your little ray of sunshine!

DK 4mm

★★ Try something new

Yarn used

Cygnets Baby Pato DK
3 balls in baby blue 785 (A)
1 ball each in white 799 (B), Lemon 798 (C),
lilac 782 (D) & Candy 797 (E)
Visit www.cygnetyarns.com
to find your local stockist

About the yarn

DK; 270m per 100g ball; 100% acrylic

Tension

17 sts x 12 rnds = 10cm measured over tr

Hook used

4mm

Sizing

6 (12, 18, 24) months
To fit 43 (45.5, 48, 50.5) cm chest
Garment measurements:
Chest circumference 48 (50.5, 53, 55.5) cm (A)
Body length 26 (28, 29, 31) cm (B)
Sleeve circumference 18 (19, 20, 21) cm (C)
Sleeve length 17 (19, 20.5, 21.5) cm (D)

Working the raindrops after the main piece is complete simplifies the work involved and allows for the raindrops to be spaced slightly differently according to the size made, based on maker's judgement.

Start crocheting...

Jumper

Jumper is worked in rnds from the top of the yoke downwards. Join each rnd with a sl st in first st.

Rnd 1: With B, 80 (88, 96, 104) ftr, join with sl st in first ftr to work in the rnd. 80 (88, 96, 104) sts

Fasten off B.

Rnd 2: Join A with sl st in first st, 3 ch (does not count as a st here and throughout), *24 (26, 28, 30) tr, [1 tr, 1 ch, 1 tr] in next st, 14 (16, 18, 20) tr, [1 tr, 1 ch, 1 tr] in next st; rep from * once more, join. 84 (92, 100, 108) sts

Rnd 3: 3 ch, 25 (27, 29, 31) tr, [1 tr, 1 ch, 1 tr] into ch-sp, 16 (18, 20, 22) tr, [1 tr, 1 ch, 1 tr] into ch-sp, 26 (28, 30, 32) tr, [1 tr, 1 ch, 1 tr] into ch-sp, 16 (18, 20, 22) tr, [1 tr, 1 ch, 1 tr] into ch-sp, 1 tr, join. 92 (100, 108, 116) sts

Rnd 4: 3 ch, 26 (28, 30, 32) tr, [1 tr, 1 ch, 1 tr] into ch-sp, 18 (20, 22, 24) tr, [1 tr, 1 ch, 1 tr] into ch-sp, 28 (30, 32, 34) tr, [1 tr, 1 ch, 1 tr] into ch-sp, 18 (20, 22, 24) tr, [1 tr, 1 ch, 1 tr] into ch-sp, 2 tr, join. 100 (108, 116, 124) sts

Rnd 5: 3 ch, 27 (29, 31, 33) tr, [1 tr, 1 ch, 1 tr] into ch-sp, 20 (22, 24, 26) tr, [1 tr, 1 ch, 1 tr] into ch-sp, 30 (32, 34, 36) tr, [1 tr, 1 ch, 1 tr] into ch-sp, 20 (22, 24, 26) tr, [1 tr, 1 ch, 1 tr] into ch-sp, 3 tr, join. 108 (116, 124, 132) sts

Rnd 6: 3 ch, 28 (30, 32, 34) tr, [1 tr, 1 ch, 1

Special stitches

Foundation treble crochet (ftr): 3 ch, yrh, insert hook in 3rd ch from hook, *yrh, pul, yrh, draw through 1 loop on hook (ch made), [yrh, draw through 2 loops] twice (tr made)**; yrh, insert hook in last ch made; rep from * for number of sts required, ending last rep at **

5 treble cluster (5trcl): [Yrh, insert hook in indicated st, yrh, pul, yrh, draw through 2 loops] 5 times in same st, yrh, draw through all 6 loops on hook

Surface sl st: Holding working yarn behind piece and hook in front of piece, insert hook through piece, place slipknot on hook, draw through piece, *insert hook through piece (in next st), yrh, draw yarn through piece and loop on hook (as a sl st); rep from * as needed

tr] into ch-sp, 22 (24, 26, 28) tr, [1 tr, 1 ch, 1 tr] into ch-sp, 32 (34, 36, 38) tr, [1 tr, 1 ch, 1 tr] into ch-sp, 22 (24, 26, 28) tr, [1 tr, 1 ch, 1 tr] into ch-sp, 4 tr, join. 116 (124, 132, 140) sts

Rnd 7: 3 ch, 29 (31, 33, 35) tr, [1 tr, 1 ch, 1 tr] into ch-sp, 24 (26, 28, 30) tr, [1 tr, 1 ch, 1 tr] into ch-sp, 34 (36, 38, 40) tr, [1 tr, 1 ch, 1 tr] into ch-sp, 24 (26, 28, 30) tr, [1 tr, 1 ch, 1 tr] into ch-sp, 5 tr, join. 124 (132, 140, 148) sts

Rnd 8: 3 ch, 30 (32, 34, 36) tr, [1 tr, 1 ch, 1 tr] into ch-sp, 26 (28, 30, 32) tr, [1 tr, 1 ch, 1 tr] into ch-sp, 36 (38, 40, 42) tr, [1 tr, 1 ch, 1 tr] into ch-sp, 26 (28, 30, 32) tr, [1 tr, 1 ch, 1 tr] into ch-sp, 6 tr, join. 132 (140, 148, 156) sts

Rnd 9: 3 ch, 31 (33, 35, 37) tr, [1 tr, 1 ch, 1 tr] into ch-sp, 28 (30, 32, 34) tr, [1 tr, 1 ch, 1 tr] into ch-sp, 38 (40, 42, 44) tr, [1 tr, 1 ch, 1 tr] into ch-sp, 28 (30, 32, 34) tr, [1 tr, 1 ch, 1 tr] into ch-sp, 7 tr, join. 140 (148, 156, 164) sts

Schematic

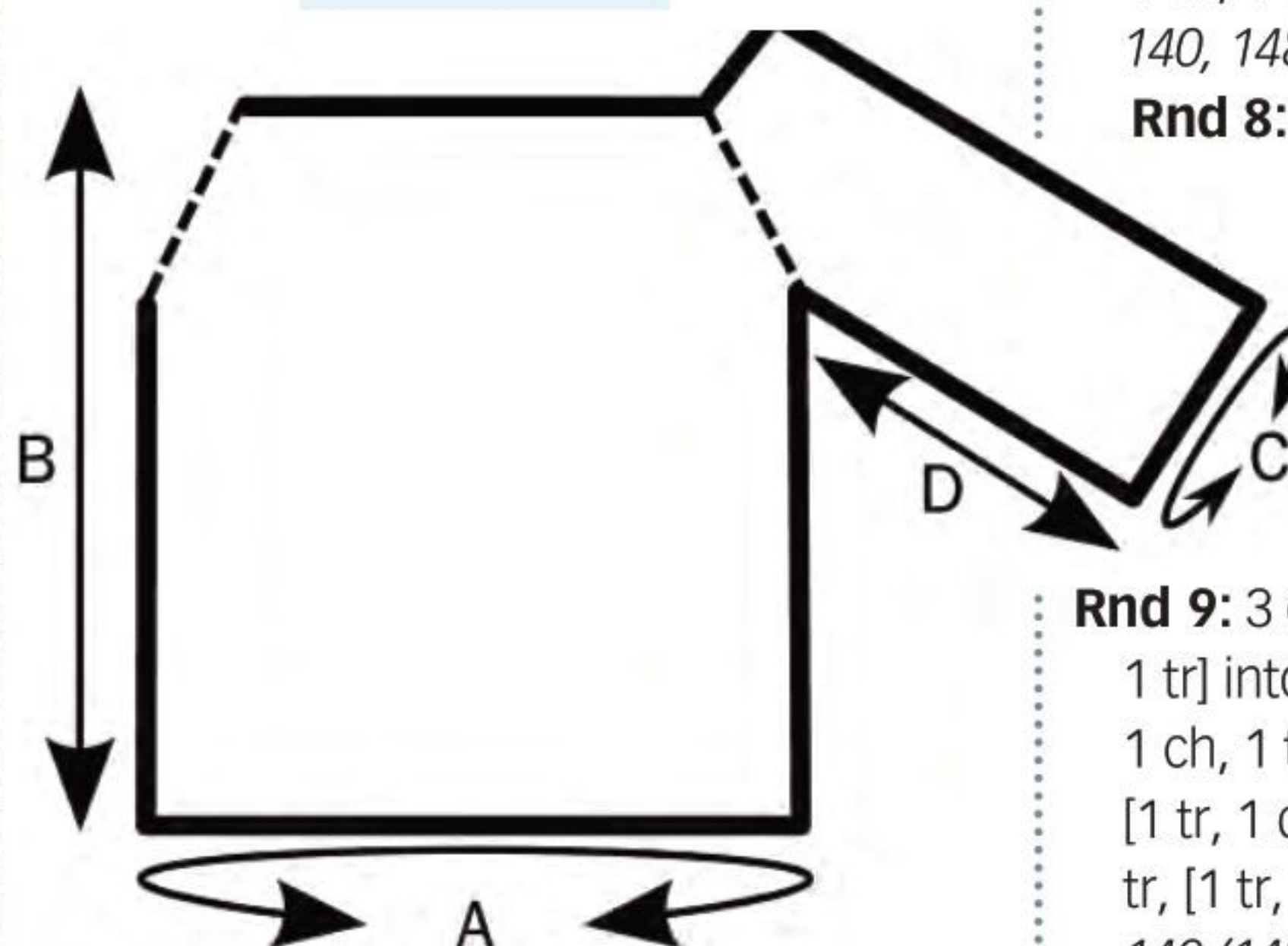

Baby

Divide for sleeves

Rnd 10: 3 ch, 32 (34, 36, 38) tr, 1 tr through ch-sp and next ch-sp at the same time, missing 30 (32, 34, 36) sts for sleeve, 40 (42, 44, 46) tr, 1 tr through ch-sp and next ch-sp at the same time, missing 30 (32, 34, 36) sts for sleeve, 8 tr, join. 82 (86, 90, 94) sts

Rnds 11-30 (32, 34, 36): 3 ch, tr around, join.

Rnd 31 (33, 35, 37): With B, 3 ch, tr around, join.

Fasten off. Weave in ends.

Sleeves (work both alike)

Rejoin A in centre st of underarm.

Rnds 1-18 (20, 22, 24): 3 ch, 30 (32, 34, 36) tr, join.

Rnd 19 (21, 23, 25): With B, 3 ch, tr around, join.

Fasten off. Weave in ends.

Sun

Rnd 1: With C and working into a magic ring, 6 dc.

Rnd 2: 2 dc in each st around. 12 sts

Rnd 3: [1 dc, 2 dc in next st] 6 times. 18 sts

Rnd 4: [2 dc, 2 dc in next st] 6 times. 24 sts

Rnd 5: [3 dc, 2 dc in next st] 6 times. 30 sts

Rnd 6: [4 dc, 2 dc in next st] 6 times. 36 sts

Rnd 7: Sl st in each st around.

Fasten off, leaving a long tail for sewing.

Cloud

With B, chain 28.

Row 1: Starting in 2nd ch from hook, 27 dc. Turn.

Row 2: 2 dc in first st, dc in each st to last st, 2 dc in last st. Turn. 29 sts

Row 3: As Row 2. 31 sts

Row 4-6: 1 ch, dc across. Turn.

Row 7: 1 dc2tog, 7 dc, 1 dc2tog. Turn, leaving rem sts unworked. 9 sts

Row 8: 1 dc2tog, 5 dc, 1 dc2tog. Turn. 7 sts

Row 9: 1 dc2tog, 3 dc, 1 dc2tog. Turn. 5 sts

Row 10: 1 dc2tog, 1 dc, 1 dc2tog. Turn. 3 sts
Fasten off.

Miss first 9 unworked sts on Row 6, join with sl st in next st, rep rows 7-10.

Fasten off. Rejoin B in first unworked st of Row 6.

Rows 7-10: 1 ch, 9 dc.

Row 11: 1 dc2tog, 5 dc, 1 dc2tog.

Row 12: 1 dc2tog, 3 dc, 1 dc2tog.

Row 13: 1 dc2tog, 1 dc, 1 dc2tog.

Sl st around edge of shape.

Fasten off, leaving a long tail for sewing.

Using photo as a guide, with tapestry



needle and tail ends, sew Sun onto Jumper, then sew Cloud overlapping it. With C, surface sl st 5 lines radiating outwards from the Sun to represent sun rays.

Raindrops

With C, D and E, and using photo as a guide

for placement and colours, create raindrops by joining yarn around the post of a st, 3 ch, work a 5trcl around the same post, sl st to same post. Fasten off and, with a tapestry needle, take both ends to the back of the work, knot together to secure, and weave in. Rep this for each of the 10 raindrops. 🌧️





Driftwood

INDIGO

UMBER

CROCHET HAPPY WITH
LYKKE

lykkekrafts.com
knittingfever.com

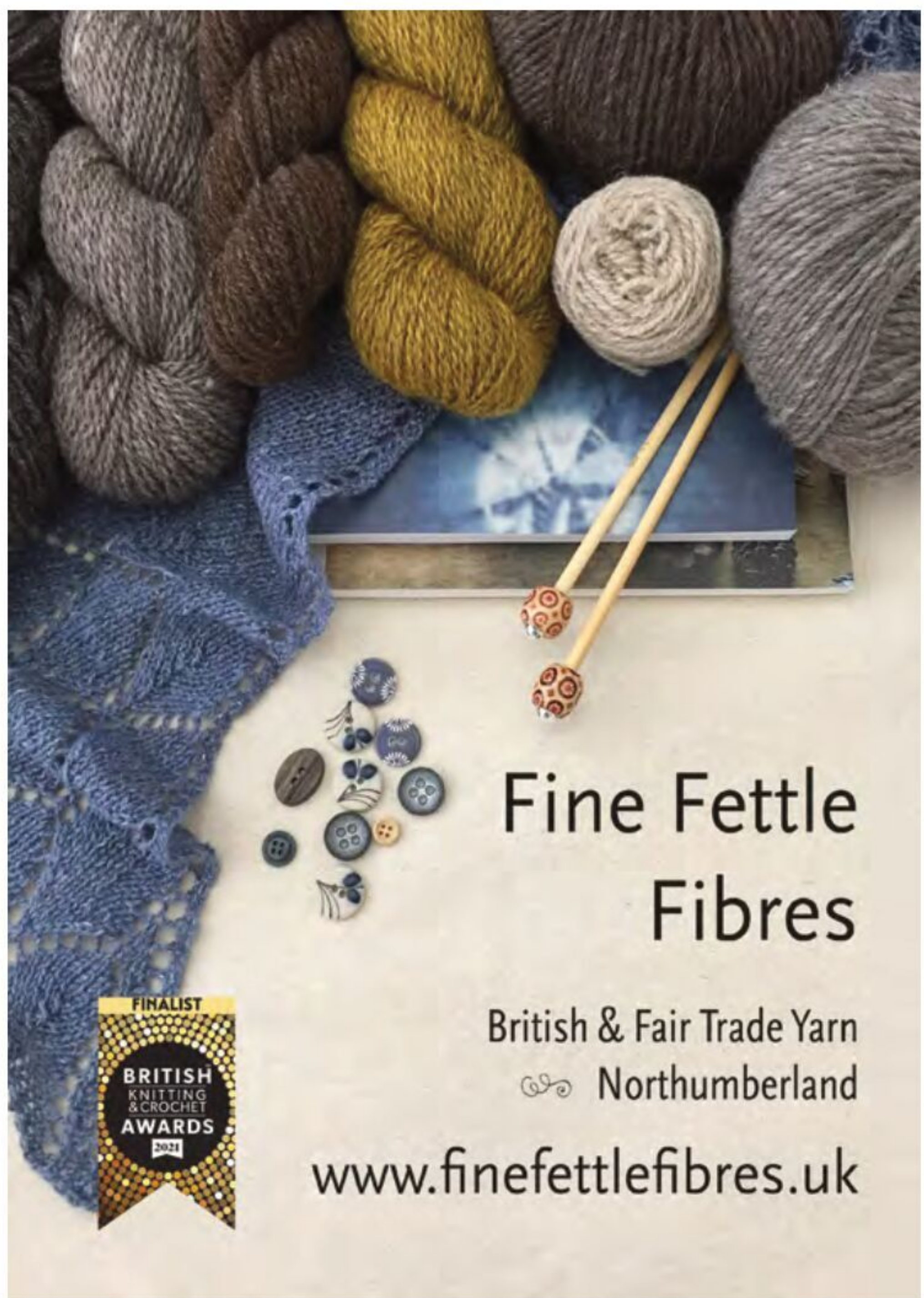

Fine Fettle
Fibres

British & Fair Trade Yarn
Northumberland

www.finefettlefibres.uk



Sew-In

Marple | Buxton | Online

- Stockists of West Yorkshire Spinners, King Cole, Stylecraft, Rico, Rowan, Sirdar and more
- Hundreds of knitting patterns, books and accessories
- Cross-stitch/Tapestry/Embroidery/Haberdashery
- Expert advice, knitting up service
- Friendly, weekly knitting club at Marple
- All major credit cards accepted, postal service a pleasure

Locally hand-dyed yarns from

Peak District Yarns
Unique hand-dyed yarns inspired by the landscape of the Peak District

0161 427 2529
46 Market Street
Marple SK6 7AD

01298 26636
1 Spring Gardens
Buxton SK17 6BJ

www.myknittingyarnandwool.co.uk

Please see website for current opening hours



Jane Howarth

SPRING SHOWERS COWL

Be prepared for whatever the spring has in store by wrapping up warm in this gorgeous cowl

 DK  3.5mm

★ Beginner friendly

Yarn used

Marriner Double Knit
3 balls in Madonna 33
Turn to pages 60-61 to find your local stockist

About the yarn

DK; 300m per 100g ball; 100% acrylic

Tension

10 rows x 16 sts = 10cm measured over patt

Hook used

3.5mm

Sizing

169x24cm

Once the pattern is set, the cowl becomes more structured and the diamond design emerges.

Remember to change to working through both loops after completing the BLO sts.

Beg 2 ch counts as first htr.

Start crocheting...

Chain 40.

Row 1: Starting in 3rd ch from hook (missed chs count as first htr), htr to end. Turn. 39 sts

Row 2: 2 ch, 6 htr in BLO, 1 ch, miss 1 st,

[7 htr, 1 ch, miss 1 st] 3 times, 7 htr in BLO. Turn. 35 sts

Row 3: 2 ch, 6 htr in BLO, 1 htr into 1ch-sp, [1 ch, miss 1 st, 5 htr, 1 ch, miss 1 st, 1 htr] 3 times, 7 htr in BLO. Turn. 33 sts

Row 4: 2 ch, 6 htr in BLO, 1 htr, 1 htr into 1ch-sp, 1 ch, miss 1 st, [3 htr, 1 ch, miss 1 st, 1 htr into 1ch-sp, 1 htr, 1 htr into 1ch-sp, 1 ch, miss 1 st] twice, 3 htr, 1 ch, miss 1 st, 1 htr into 1ch-sp, 1 htr, 7 htr in BLO. Turn. 33 sts

Row 5: 2 ch, 6 htr in BLO, 2 htr, [1 htr into 1ch-sp, 1 ch, miss 1 st, 1 htr, 1 ch, miss 1 st, 1 htr into 1ch-sp, 3 htr] twice, 1 htr into 1ch-sp, 1 ch, miss 1 st, 1 htr, 1 ch, miss 1 st, 1 htr into 1ch-sp, 2 htr, 7 htr in BLO. Turn. 33 sts

Row 6: 2 ch, 6 htr in BLO, 3 htr, 1 htr into 1ch-sp, 1 ch, miss 1 st, [1 htr into 1ch-sp, 5 htr, 1 htr into 1ch-sp, 1 ch, miss 1 st] twice, 1 htr into 1ch-sp, 3 htr, 7 htr in BLO. Turn. 36 sts

Row 7: 2 ch, 6 htr in BLO, 3 htr, 1 ch, miss 1 st, [1 htr into 1ch-sp, 1 ch, miss 1 st, 5 htr, 1 ch, miss 1 st] twice, 1 htr into

1ch-sp, 1 ch, miss 1 st, 3 htr, 7 htr in BLO. Turn. 33 sts

Row 8: 2 ch, 6 htr in BLO, 2 htr, 1 ch, miss 1 st, [1 htr into 1ch-sp, 1 htr, 1 htr into 1ch-sp, 1 ch, miss 1 st, 3 htr, 1 ch, miss 1 st] twice, 1 htr into 1ch-sp, 1 htr, 1 htr into 1ch-sp, 1 ch, miss 1 st, 2 htr, 7 htr in BLO. Turn. 33 sts

Row 9: 2 ch, 6 htr in BLO, 1 htr, [1 ch, miss 1 st, 1 htr into 1ch-sp, 3 htr, 1 htr into 1ch-sp, 1 ch, miss 1 st, 1 htr] 3 times, 7 htr in BLO. Turn. 33 sts

Row 10: 2 ch, 6 htr in BLO, 1 ch, miss 1 st, [1 htr into 1ch-sp, 5 htr, 1 htr into 1ch-sp, 1 ch, miss 1 st] 3 times, 7 htr in BLO. Turn. 35 sts

Rep rows 3-10 nineteen times more, then rep rows 3-9 once more.

Fasten off, leaving a long tail.

Making up

Fold in half and lay short ends tog with sts aligned. Sew seam, fasten off and weave in ends. 

Chart

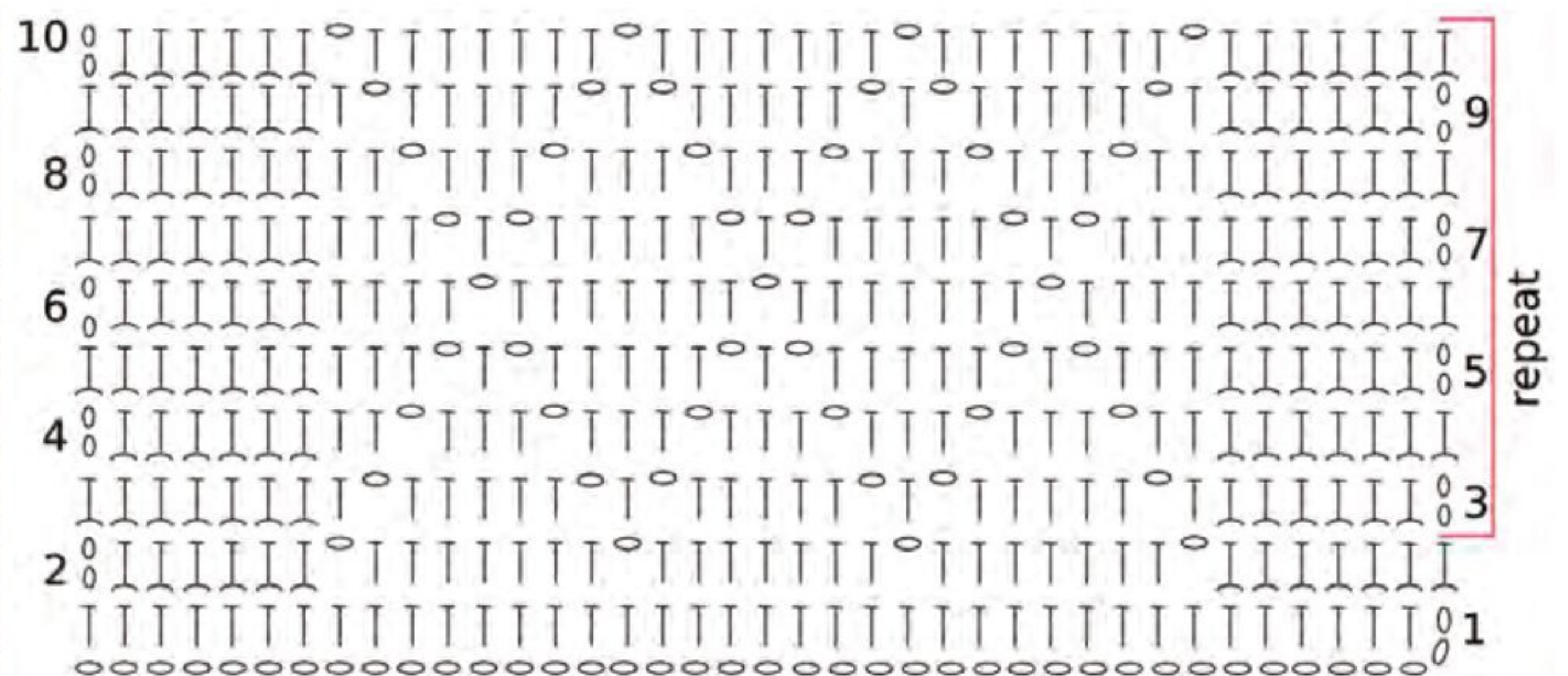

Key ○ ch | htr | htr in BLO



Bringing textile creations to your heart and your home

Stocking a stunning range of yarns from lace weight to heavyweight, thrums and thrum hanks, hand-dyed and hand-spun. We also offer regular woolly workshops, kits, and handcrafted accessories all of which will make beautiful gifts.



**3 Bags Wool, 89 High Street
Aberlour, Speyside, Moray, AB38 9QB
01340881749**

www.3bagswool.com



We sell exclusive Dorset button kits, books and patterns, luxury yarn, hand-dyed threads, tools and materials for the discerning crafter.

We run button and fibre craft workshops from beginner to advanced.

Tel: 01264 748 070

www.beakerbutton.co.uk info@beakerbutton.co.uk





✓ *Simply select material*

✓ *Customise your label online*

✓ *Order from 1 piece*

➔ **dortex.com**



NATIONAL WOOL SHOW

coming to the
Coventry Building Society
Arena

9th and 10th April 2022

4000 square meters of
squishiness

www.nationalwoolshow.co.uk

Your crochet COMMUNITY

Keep in touch with your local yarn community with our guide to news, charity campaigns, online and community events and more



MAKE IT

Representing a period of historic change, the Devon Guild of Craftsmen decided to change its name to MAKE Southwest. Feeling that the previous name didn't reflect the number of fabulous women who are part of the charity, MAKE Southwest wanted to recognise the talent and energy from its diverse group of members. The charity was established in 1986 by a guild of distinguished craft makers who had collaborated since 1955 and, with the help of Arts Council funding, MAKE Southwest increasingly offers craft education to the public and encourages participation by people of all ages and backgrounds to participate in craft!

www.crafts.org.uk



CHAMPION CRAFTER

The annual Oldie of the Year Awards took place at The Savoy in London at a lunchtime ceremony attended by VIP and celebrity guests. 92-year-old Margaret Seaman – who knitted an extraordinary 18-foot model of Sandringham, currently on display at the Queen's Sandringham estate – was awarded the Oldie Champion Knitter of the Year Award. Margaret's creation is not only a magnificent feat – two years in the making – but a charitable effort that has helped to raise funds for the three local hospitals in the Great Yarmouth area.

MIDWIFE MAGIC!

Wow! When CraftWorld asked crafters to help out the hardworking midwives at St Mary's Maternity Unit, we did not expect such an incredible response! In August, CraftWorld super crafters were asked to send in baby



items to help keep newborns as warm as possible and the staff at this fantastic maternity unit have been overwhelmed with the lovingly crafted items. A wave of love and support has been streaming to the lovely mothers and their babies born on the unit featuring some of the most beautifully handmade hats we have ever seen! Annie Guthrie from the unit said, "Thank you so much to everyone who has so kindly made something for us. We want to pass on a huge thank you from St Mary's. The response has been amazing and we are so shocked by how generous the Craftworld community has been."

Read about this appeal at www.craftworld.com/cms/baby-hat-appeal

Proud to be working with



UK Hand Knitting

THE YARN CIRCLE

Join Wallace and Gromit in showing your love and support for your local yarn shop, and claim your **FREE Knit Pro** gift when you shop in store!

ABARAERON

ROSEMARY'S

Knitting yarn specialists stocking Debbie Bliss, Noro, Louisa Harding, Wendy and Sirdar yarn as well as cross stitch and haberdashery supplies.

We hold regular knitting and crochet workshops.

Birmingham House, 22 Alban Square, Abaraeron SA46 OAH

01545 905051

www.rosemaryswoolshop.co.uk

BAKEWELL

Wye Wool

Well stocked shop in the heart of Bakewell. We have a good range of Stylecraft, Adriafile and king cole yarns with some local dyed yarns as well. Stockists of many knit pro items too.

07913 307752

11 Water Street, Bakewell, Derbyshire, DE45 1EW
wool@wyewool.uk

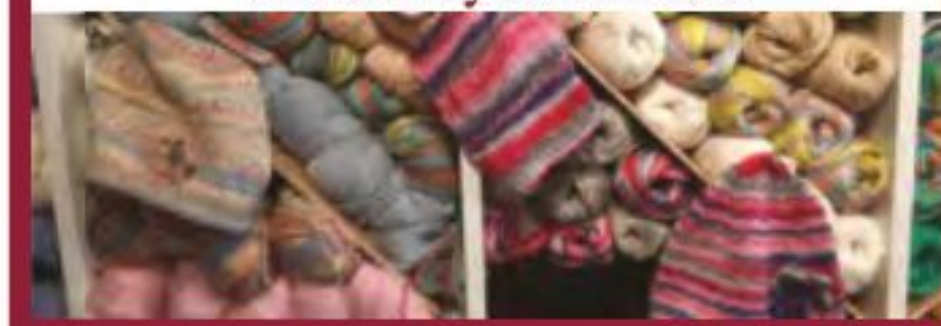

BRISTOL

Visit us in store or online to see our range of Stylecraft, King Cole, West Yorkshire Spinners, Knit Pro and other accessories.

19 Badminton Road, Downend, Bristol BS16 6BB
Tel. 0117 329 3857

www.fabrics-plus.co.uk
Fabrics-Plus Limited
fabricspluslimited

EVESHAM

A haven of yarn in the English countryside. We have a great selection of yarns, patterns, & accessories all at low prices!

Individual lessons and knit & crochet groups - loyalty scheme now available!

Free parking

Cadbury Courtyard, Blackminster Business Park Evesham, WR11 7RE
Tel 07450 794505

FELTON

Studio 6, Gallery 45, 45 Main Street, Felton, Northumberland, NE65 9PP

www.finefettlefibres.uk
judith@finefettlefibres.uk
Facebook: finefettlefibres
01670 600001

HAMPSHIRE



Beaker Button

We sell exclusive Dorset button kits, books and patterns, luxury yarn, hand-dyed thread, tools and materials for the discerning crafter. We run button and fibre craft workshops from beginner to advanced

www.beakerbutton.co.uk
info@beakerbutton.co.uk
01264 748 070

HARROGATE

An independent local yarn shop with yarn for all tastes and budgets. Crochet and knitting workshops in a relaxed creative environment.

Stockists of Scheepjes, Erika Knight, UK Alpaca, StyleCraft, King Cole, & various hand-dyed yarns.

17 Knaresborough Road, Harrogate HG2 7SR
01423 885 565

yarnetc@mail.com
eweherditatyarnetc.com

HEREFORDSHIRE

www.railwayyarns.co.uk
railwayyarns@hotmail.com

07854 863 312
Unit 6, Station Ind. Estate, The Homend, Ledbury, HR8 1AR

An independent knitting shop just a few steps from the Ledbury train station! We sell a wide range of wool from the UK and abroad, as well as knitting and crocheting equipment and accessories. We also host a range of classes in our large hireable crafting room.

HUDDERSFIELD

Supplies for knitting, crochet, sewing, embroidery, patchwork, quilting, and fabric crafts

Decorative goods personally sourced in India and Nepal in The Shawl Room
The Gallery has a new exhibition by local crafters and artists every month

Open 9.30-5.00 Monday to Saturday

355 Wakefield Road
Denby Dale, Huddersfield, HD8 8RP
01484 767502, 07979 293017

mary@unravelcrafts.co.uk
www.unravelcrafts.co.uk
www.facebook.com/UnravelCrafts

ISLE OF WIGHT

A friendly local shop stocking Stylecraft, James C Brett, Adriafile and Woolcraft yarns plus DMC silks. Weekly Sit 'n' Stitch sessions and Crochet groups. Range of haberdashery and lots of knitting and crochet patterns.

11 Sandown Road
Lake, Isle of Wight, PO36 9JL
01983 716890
www.facebook.com/knitknacksiow
www.knitknacksiow.co.uk

TO ADVERTISE IN **CROCHET NOW** PLEASE CALL ON **0161 674 9060**

MACCLESFIELD



Your one-stop-shop for yarn; we have the largest range in the area, including Stylecraft, Rico, King Cole, DMC, and many more including hand-dyed luxury fibres.
81 Mill Street, Macclesfield, SK11 6NN
www.craftycornermacc.co.uk
craftycorner_macc@icloud.com

PONTYCLUN

Visit us & be inspired



Ammonite Yarns
Bringing Wool to Wales
7 Llantrisant Road, Pontyclun CF72 9DP
www.ammoniteyarns.co.uk
01443 520200

SALE



Blue Button Designs

3-7 Tatton Road Sale Cheshire M33 7EB
T 07540 634351 F @BlueButtonDesigns
E djpproducts@msn.com
Lovely yarns and accessories for all your crochet projects including Sirdar, Rico, James C Brett Wendy and more.
Why not pay us a visit and be surprised!

WEST YORKSHIRE



Probably the UK's largest display of yarn and patterns for knitting and crochet from Sirdar, King Cole and lots of other brands.
Discount packs always available.
Open 7 days 10-5

Coldspring Mill
Haworth Road, Cullingworth
West Yorkshire BD13 5EE
T 01535 275646
www.coldspringmill.co.uk



FREE
KnitPro™
CROCHET HOOKS

Spend £15 in store and claim your pair of KnitPro Waves crochet hooks in 3mm & 4mm, all for free!

from
FREE GIFT **crochet**
now

Claim your FREE KnitPro Waves crochet hooks by shopping at one of these participating stores.

Name:

Address:

.....

.....

Email:

*Minimum instore spend of £15 applies. To take advantage of this offer please send us your receipt along with this voucher to Knit Now, Practical Publishing Suite G2, Vitality House, 217 Wellington Road South, Stockport SK2 6NG with your contact details. Gift will be sent direct from Practical Publishing Ltd within 28 days. While stocks last. Please ensure all your details are completed in black ink. UK offer only. *Only stores listed on Yarn Circle pages of Crochet Now issue 76 are participating in this offer.

SOUTH EAST WALES



Beautiful yarns, fabrics & inspirational craft kits in our spacious shop - Welsh wool, Rowan Yarns, WYorks Spinners wools, many more.
Thurs/Sat Craft Clubs are back! Drop in to our Pavement Cafe.

14 Nevill Street, Abergavenny
NP7 5AD
Webshop: bit.ly/woolcraftshop
Tel/Text: 0739 777 9931

To advertise in
crochet
now



please call Amanda on
0161 474 6995

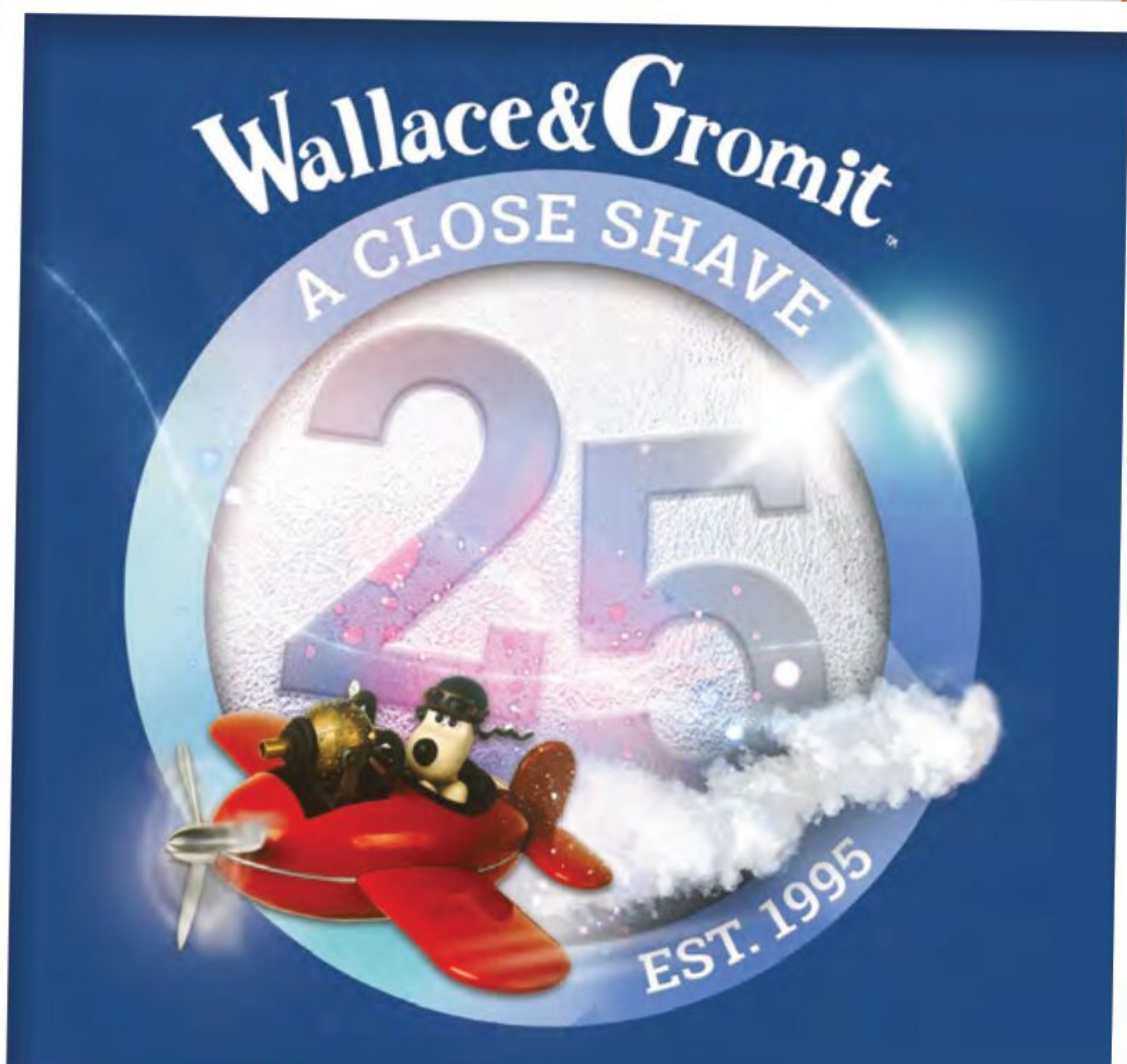

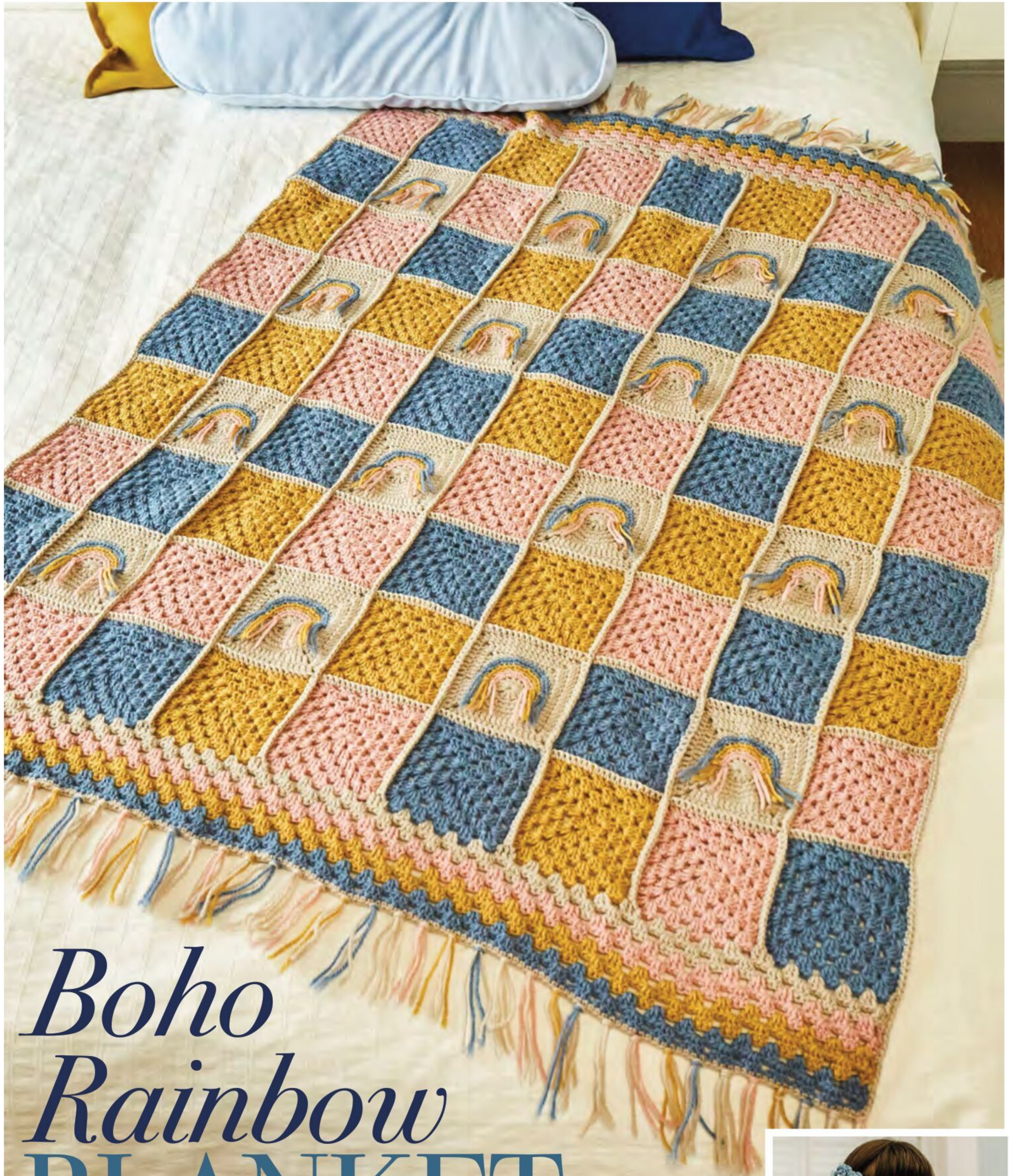

Boho *Rainbow* BLANKET

Add a splash of joy into your home with this beautiful Boho Rainbow Blanket



Becca Parker

 DK  4mm

★★ Try something new

Yarn used

West Yorkshire Spinners Bo Peep Pure
6 balls in Sand 208 (A)
5 balls each in Blush 287 (B), Dandelion 446
(C) & River 194 (D)
Turn to pages 60-61 to find your
local stockist

About the yarn

DK; 112m per 50g ball; 100% Falkland
Islands Wool

Tension

Completed square measures 10cm

Hook used

4mm

Sizing

Finished blanket measures 115x90cm, not
including fringe

The blanket is made up of a 9x9 block
of granny and rainbow motif squares,
then granny stripes are added to two
ends to create a rectangle shape. The
piece is then embellished with fringe
using all four yarn colours.

Beg 2 ch counts as first dc, join at end of
rnd in top of beg 2 ch.

Beg 3 ch counts as first tr, join at end of rnd
in top of beg 3 ch.

Beg 5 ch counts as first tr and 2ch-sp, join
at end of rnd in 3rd of beg 5 ch.

Weave in ends as you go or work them into
the seams.

 Start crocheting...

Granny Square (make 65: 21 in C
and 22 each in B & D)

Chain 4, join with sl st to form a ring.

Rnd 1: Working into ring, 3 ch, 2 tr, 2 ch,
[3 tr, 2 ch] 3 times, join. 12 sts

Rnd 2: Sl st across to first 2ch-sp, [sl st, 5
ch, 3 tr] into first 2ch-sp, 1 ch, *[3 tr, 2 ch,
3 tr] into next corner 2ch-sp, 1 ch; rep
from * twice more, 2 tr into first 2ch-sp to

complete corner, join. 24 sts

Rnd 3: [Sl st, 5 ch, 3 tr] into first 2-ch sp,
1 ch, 3 tr into next 1ch-sp, 1 ch, *[3 tr, 2
ch, 3 tr] into next corner 2ch-sp, 1 ch, 3
tr into next 1ch-sp, 1 ch; rep from * twice
more, 2 tr into first 2ch-sp, join. 36 sts

Rnd 4: [Sl st, 5 ch, 3 tr] into first 2ch-sp, [1
ch, 3 tr into next 1ch-sp] twice, 1 ch, *[3 tr,
2 ch, 3 tr] into next corner 2ch-sp, [1 ch, 3
tr into next 1ch-sp] twice, 1 ch; rep from *
twice more, 2 tr into first 2ch-sp, join. 48 sts

Rnd 5: [Sl st, 1 ch (counts as dc), 2 dc, 2 ch,
3 dc] into first 2ch-sp, [1 ch, 3 dc into next
1ch-sp] 3 times, *1 ch, [3 dc, 2 ch, 3 dc]
into corner 2ch-sp, [1 ch, 3 dc into next
1ch-sp] 3 times; rep from * twice more,
join with sl st in beg 1 ch. Fasten off. 15
sts, 4 1ch-sps per side

Rainbow Square (make 16)

With A, chain 4, sl st to first ch to form a ring.

Rnd 1: Working into ring, 3 ch, 11 tr, join.
12 sts

Rnd 2: 2 ch, [2 dc in next st] 5 times,
change to B (work over A), [2 dc in next
st] 6 times, change to A, join. Fasten off
B. 24 sts

Rnd 3: [2 ch, 1 dc] in first st, [1 dc, 2 dc in
next st] 5 times, 1 dc, change to C (work
over A), [2 dc in BLO of next st, 1 dc in
BLO] 6 times, change to A, join. Fasten off
C. 36 sts

Rnd 4: [2 ch, 1 dc] in first st, [2 dc, 2 dc in
next st] 5 times, 2 dc, change to D (work
over A), [2 dc in BLO of next st, 2 dc in
BLO] 6 times, change to A, join. Fasten off
D. 48 sts

Rnd 5: 2 ch, 2 dc, 2 htr, 1 tr, 2 ch, 1 tr, 2 htr,
6 dc, 2 htr, 1 tr, 2 ch, 1 tr, 2 htr, 3 dc, work
rem sts in BLO, 3 dc, 2 htr, 1 tr, 2 ch, 1 tr, 2
htr, 6 dc, 2 htr, 1 tr, 2 ch, 1 tr, 2 htr,
3 dc, join.

Rnd 6: 3 ch, 5 tr, [1 tr, 2 ch, 1 tr] into corner
2ch-sp, *12 tr, [1 tr, 2 ch, 1 tr] into corner
2ch-sp; rep from * twice more, 6 tr, join.
56 sts

Rnd 7: 3 ch, 6 tr, [1 tr, 2 ch, 1 tr] into corner
2ch-sp, *14 tr, [1 tr, 2 ch, 1 tr] into corner
2ch-sp; rep from * twice more, 7 tr, join.
64 sts, 16 sts per side

Block all squares to measure 10cm.

Joining

Arrange squares into one large 9x9 square,
referring to photograph as a guide. Join
squares in rows, first horizontally then
vertically, using a dc seam as follows: Hold
2 adjoining squares with WS tog (seam will

show on RS), with A and starting in 2ch-
sp, dc across edge, working through both
pieces at the same time and ending in next
2ch-sp; when joining a Granny Square with
a Rainbow Square, miss the first, third and
fourth 1ch-sps on the Granny Square to
match the st count of the rainbow square,
this will give an even finish.

Edging

Row 1: Join A with sl st in 2ch-sp of top RH
square, 3 ch, 1 tr into same 2ch-sp, 1 ch,
*[3 tr into next 1ch-sp, 1 ch] 4 times, 1 tr
into next 2ch-sp, 1 tr in dc seam, 1 tr into
next corner 2ch-sp, 1 ch; rep from * 7
times more, [3 tr into next 1ch-sp, 1 ch] 4
times, 2 tr into last corner 2ch-sp. Turn.

Row 2: 3 ch, 1 tr, 1 tr into first 1ch-sp, 1 ch,
*3 tr into next 1ch-sp, 1 ch; rep from * to
last 1ch-sp, 1 tr into last 1ch-sp, 2 tr. Turn.
Fasten off.

Row 3: Join B with sl st in first st, [3 ch, 1
tr] in first st, 1 ch, *3 tr into next 1ch-sp, 1
ch; rep from * to last 3 sts, miss 2 sts, 2 tr
in last st. Turn.

Row 4: As Row 2.

Rows 5-6: With C, as rows 3-4.

Rows 7-8: With D, as rows 3-4.

Fasten off.

Rep rows 1-8 on the opposite side of
blanket. Fasten off. Weave in ends.

Border

Join A with sl st in first st of either Granny
Edge, 1 ch, evenly dc around all sides, join
with sl st to beg dc. Fasten off.

Fringe (optional)

For Rainbow Squares, cut 32 lengths each
of B, C and D, each 8cm long. Make a
Lark's Head Knot on each corresponding
rainbow end.

For top and bottom of blanket, cut 16cm
lengths: 116 in A, 24 in B and 22 each in C and
D. Pair each length with an additional length
of A (for 2 lengths each), make a Lark's Head
Knot in every 4th st on short sides. 

Special stitches

Lark's Head Knot: Fold 2 lengths of
yarn in half, insert hook into indicated
st and into loop created by fold, pull
loop partially through st, bring ends
of yarn through loop and pull tightly
to secure



Special stitches

Bobble (bbl): [Yrh, insert hook in indicated st, yrh, pull, yrh, draw through 2 loops on hook] twice in same st, yrh, draw through all 3 loops on hook

Popcorn (PC): Work 3 tr into indicated st, remove hook from loop, insert hook from front to back in first tr made, put loop back onto hook, pull loop through first tr

Invisible decrease (inv-dc2tog): Insert hook in FLO of both of next 2 sts, yrh, pull through both front loops (2 loops on hook), yrh, draw through both loops on hook



Victoria Kairis

IMOGEN THE ICE SKATER

Imogen loves to skate with her friends in the winter, before heading home and having hot chocolate and marshmallows by the fire!

 4-ply  2.5mm

★★ Try something new

Yarn used

Yarn and Colors Must-Have
1 ball each in Pearl 043 (A), white 001 (B),
Shark Grey 096 (C), Larimar 062 (D)
& Golden Glow 011 (E)
Available from www.lovecrafts.com

About the yarn

4-ply; 125m per 50g ball;
100% cotton

Tension

13 sts x 16 rows = 5cm measured over dc

Hook used

2.5mm

Other supplies

toy stuffing
1 pair of safety eyes, 7mm
tapestry needle
stitch markers
black stranded cotton

Sizing

25cm tall x 12cm wide

Tension is not critical for this project, but sts should be tight enough to avoid stuffing showing through.

When you sew pieces together, pin them in place first so that you can see if you like the position before you sew.

When you sew the laces on, don't fasten off until you have done both boots, so you can make sure that they match.

 Start crocheting...

This pattern is worked in the amigurumi style, in a spiral without slip stitching or turning chains. Use a stitch marker or waste yarn to keep track of the first stitch of each round.

Head

Rnd 1: With A and working into a magic ring, 6 dc. 6 sts

Rnd 2: [2 dc in next st] 6 times. 12 sts

Rnd 3: [1 dc, 2 dc in next st] 6 times. 18 sts

Rnd 4: [2 dc, 2 dc in next st] 6 times. 24 sts

Rnd 5: [3 dc, 2 dc in next st] 6 times. 30 sts

Rnd 6: [4 dc, 2 dc in next st] 6 times. 36 sts

Rnd 7: [5 dc, 2 dc in next st] 6 times. 42 sts

Rnd 8: [6 dc, 2 dc in next st] 6 times. 48 sts

Rnds 9-16: Dc around.

Rnd 17: 18 dc, 2 dc in next st, 9 dc, 2 dc in next st, 19 dc. 50 sts

Rnd 18: 24 dc, 1 bbl, 25 dc. Push bbl to RS to make the nose.

Rnds 19-20: Dc around.

Rnd 21: 18 dc, 1 inv-dc2tog, 9 dc, 1 inv-dc2tog, 19 dc. 48 sts

Rnd 22: [6 dc, 1 inv-dc2tog] 6 times. 42 sts

Rnd 23: [5 dc, 1 inv-dc2tog] 6 times. 36 sts

Rnd 24: [4 dc, 1 inv-dc2tog] 6 times. 30 sts

Rnd 25: [3 dc, 1 inv-dc2tog] 6 times. 24 sts

Secure the safety eyes in the gap between rnds 16 and 17, above the increases of Rnd 17 with 9 sts between the eyes, then stuff Head.

Rnd 26: [2 dc, 1 inv-dc2tog] 6 times. 18 sts

Rnd 27: [1 dc, 1 inv-dc2tog] 6 times. 12 sts

Rnd 28: 6 inv-dc2tog. 6 sts

Fasten off. Weave in ends.

Arms (make 2)

Rnds 1-2: With A, rep rnds 1-2 of Head.

Rnds 3-4: Dc around. 12 sts

Rnd 5: 11 dc, 1 PC (thumb made).

Rnd 6: 11 dc, 1 dc in PC.

Rnd 7: [1 inv-dc2tog, 4 dc] twice. 10 sts
Change to D, fasten off A.

Rnd 8: [2 dc in next st, 4 dc] twice. 12 sts

Rnds 9-10: Dc around.

Rnd 11: [2 dc in next st, 5 dc] twice. 14 sts

Rnds 12-19: Dc around.

Rnd 20: [6 dc, 2 dc in next st] twice. 16 sts
Fasten off.

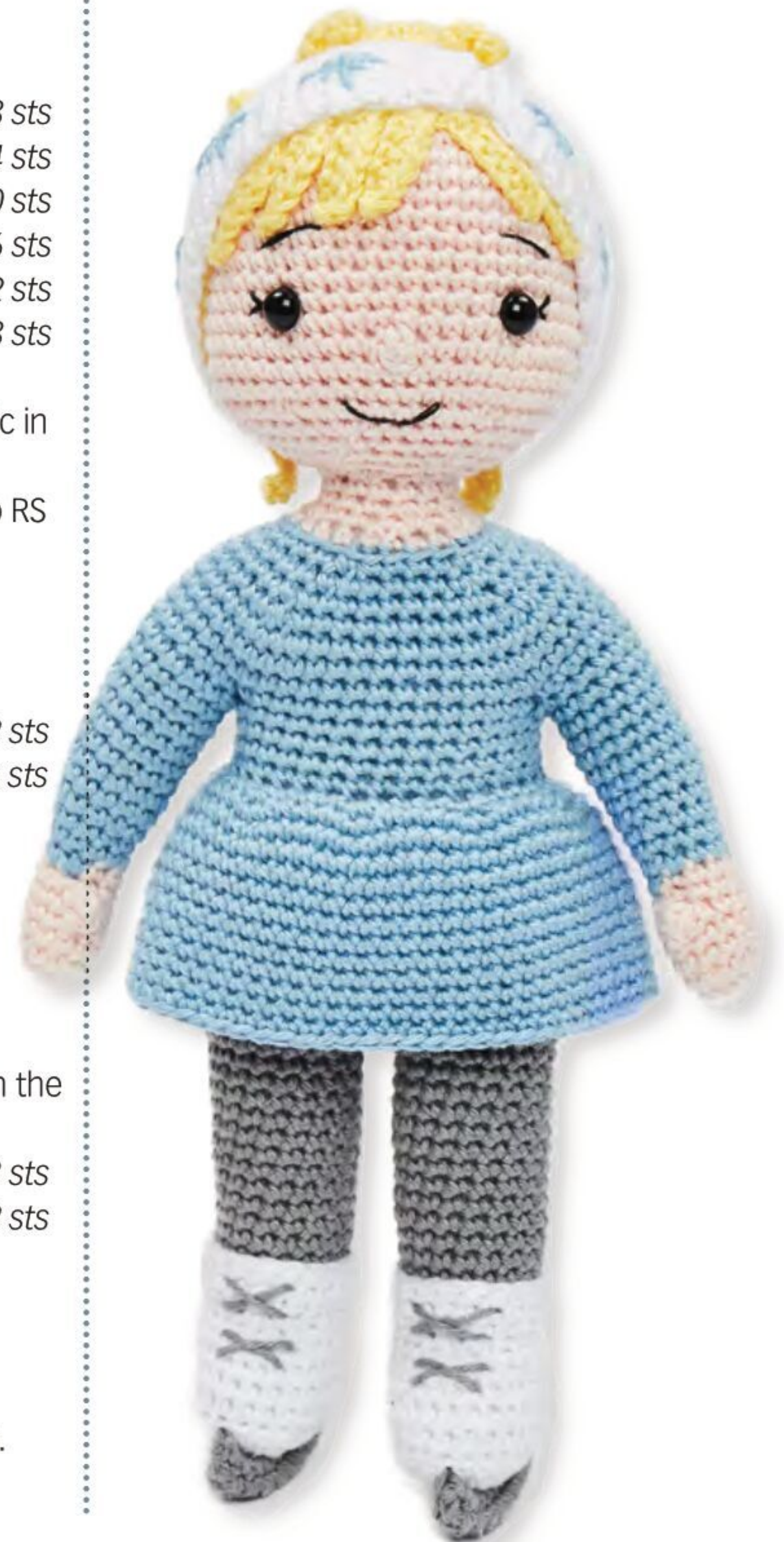

Toy

Skates (make 2)

With B, chain 6.

Rnd 1: Starting in 2nd ch from hook, 4 dc, 3 dc in next ch, rotating as you go, work in the other side of the chain, 3 dc, 2 dc in next ch. *12 sts*

Rnd 2: {2 dc in next st, 3 dc, [2 dc in next st] twice} 2 times. *18 sts*

Rnd 3: {1 dc, 2 dc in next st, 3 dc, [1 dc, 2 dc in next st] twice} 2 times. *24 sts*

Rnd 4: Dc in BLO around.

Rnds 5-7: Dc around.

Rnd 8: 7 dc, 4 inv-dc2tog, 9 dc. *20 sts*

Rnd 9: 7 dc, 2 inv-dc2tog, 9 dc. *18 sts*

Rnd 10: [8 dc in FLO, 2 dc in FLO of next st] 2 times. *20 sts*

Rnds 11-12: Dc around.

Fasten off. Weave in ends.

Legs (make 2)

Rnd 1: Join C with sl st to first back loop on Rnd 9, starting in same st as join, dc in BLO around. *18 sts*

Rnds 2-14: Dc around. *18 sts*

Rnd 15: 5 dc, 2 dc in next st, 8 dc, 2 dc in next st, 3 dc. *20 sts*

Rnds 16-17: Dc around.

Fasten off. Stuff Skates and lower Legs.

Blades (make 2)

With C, chain 11.

Rnd 1: Starting in 2nd ch from hook, 9 dc, 2 dc in next ch, rotating as you go, work in the other side of the chain, 9 dc. *20 sts*

Rnd 2: Dc around.

Fasten off, leaving a long tail. Sew Blade to bottom of Skate. With C, embroider laces onto the front of each Skate, using photograph as a guide.

Body

With C, join Legs tog by placing both feet facing in the same direction, join with sl st in the inside st of the right Leg (doll's perspective) and the corresponding st of the left Leg at the same time. Each rnd will beg at the centre back of the doll.

Rnd 1: Begin working around the left Leg, 19 dc, move to the next unworked st of the right Leg, 19 dc, miss the joining st. *38 sts*

Rnd 2: [2 dc, 2 dc in next st] twice, 26 dc, [2 dc in next st, 2 dc] twice. *42 sts*

Rnds 3-8: Dc around.

Rnd 9: [2 dc, 1 inv-dc2tog] twice, 3 dc, 1 inv-dc2tog, 18 dc, 1 inv-dc2tog, 3 dc, 1 inv-dc2tog, 2 dc, 1 inv-dc2tog. *36 sts*

Change to D, fasten off C.

Rnds 10-11: Dc around.



Rnd 28: 4 dc, 1 sl st, leave rem sts unworked. *5 sts*

Fasten off, leaving a long tail. Sew the neck to the base of Head, making sure to stuff the neck well before closing. Weave in ends. Using black stranded cotton, embroider eyebrows, eyelashes and mouth.

Hair

Rnds 1-8: With E, rep rnds 1-8 of Head.

Rnd 9: [15 dc, 2 dc in next st] 3 times. *51 sts*

Rnds 10-14: Dc around.

Rnd 15: 8 dc, 2 dc in next st, [16 dc, 2 dc in next st] twice, 8 dc. *54 sts*

Rnds 16-17: Dc around.

Rnd 18: 5 dc, 6 ch, starting in 2nd ch from hook (here and throughout), 5 dc across ch, 16 dc, [7 ch, 6 dc across ch, 2 dc] 6 times, 16 dc, 6 ch, 5 dc across ch, 5 dc. *100 sts*

Fasten off, leaving a long tail. Use tail to sew Hair onto Head so that the long hairs are at the front to create the fringe. Tack down the fringe at the end of each hair. Weave in ends.

Bun

Rnds 1-5: With E, rep rnds 1-5 of Head.

Rnd 6: Dc around. *30 sts*

Rnd 7: [3 dc, 1 inv-dc2tog] 6 times. *24 sts*

Rnd 8: [8 ch, starting in 2nd ch from hook, 7 dc across ch, 4 dc] 6 times. *66 sts*

Fasten off, leaving a long tail. Sew Bun to the crown of Head, stuffing lightly as you go. Weave in ends.

Skirt

Holding Body upside down, join D with sl st to the first front loop on Rnd 11 of Body.

Rnd 1: [3 dc, 3 dc in next st] 9 times. *54 sts*

Rnd 2: 4 dc, [2 dc in next st, 5 dc] 8 times, 2 dc in next st, 1 dc. *63 sts*

Rnds 3-13: Dc around.

Fasten off and weave in the ends.

Headband

With B, chain 9.

Row 1: Starting in 2nd ch from hook, 8 dc. Turn. *8 sts*

Rows 2-52: 1 ch (does not count as st), dc in each st across. Turn.

Fasten off, leaving a long tail. Sew the short sides of Headband tog and weave in the ends. In the middle of the Headband (Row 26) sew a running st through the sts and pull tight to gather the sts tog, secure the gathering stitches with a knot and securely weave in ends. With D, embroider stars onto Headband.

Rnd 12: Working in BLO, 10 dc, 1 inv-dc2tog, 16 dc, 1 inv-dc2tog, 6 dc. *34 sts*

Rnds 13-14: Dc around.

Rnd 15: 9 dc, join Arm to Body by working through from the WS of Arm (make sure the thumb is facing forwards) and the RS of Body (working through 2 layers), 3 dc in both Arm and Body, 14 dc in Body, 3 dc in both 2nd Arm and Body, 5 dc in Body.

Rnd 16: 9 dc, miss 3 joining sts, 13 dc in unworked sts of Arm, 14 dc in Body, miss 3 joining sts, 13 dc in unworked sts of Arm, 5 dc in body. *54 sts*

Rnds 17-19: Dc around.

Rnd 20: [7 dc, 2 inv-dc2tog, 9 dc, 2 inv-dc2tog, 3 dc] twice. *46 sts*

Rnd 21: [7 dc, 1 inv-dc2tog, 9 dc, 1 inv-dc2tog, 3 dc] twice. *42 sts*

Rnd 22: [5 dc, 1 inv-dc2tog] 6 times. *36 sts*

Rnd 23: [4 dc, 1 inv-dc2tog] 6 times. *30 sts*
Change to A, fasten off D.

Rnd 24: [3 dc in BLO, 1 inv-dc2tog in BLO] 6 times. *24 sts*

Finish stuffing Body.

Rnd 25: [2 dc, 1 inv-dc2tog] 6 times. *18 sts*

Rnd 26: [4 dc, 1 inv-dc2tog] 3 times. *15 sts*

Rnd 27: Dc around.

THE BOOK CLUB

This month, we're diving into Modern Crochet Style, the brilliant new book from Lindsey Newns!



Modern Crochet Style
By Lindsey Newns
£14.99, White Owl
ISBN:9781526793133

This month, we have overcome our January blues by diving into the cheerful new book by Lindsey Newns, titled *Modern Crochet Style*. The book contains 15 simple yet beautiful projects that are divided into the four seasons, taking you through an entire year of crochet projects!

This book truly does feel 'modern' in every sense, containing the kind of projects you don't see every day! There are plenty of quick-make accessories and scrap-busting techniques to fall in love with. As we grow more and more conscious of the importance of being environmentally conscious, Lindsey shares tips on how to be more sustainable, and ways to use eco-friendly materials in your projects.

Our favourite eco-friendly pattern would have to be the gorgeous Scrap Rug, that guides you through making the most of your scraps, saving your pocket as well as the planet!

This striking book is suitable for crocheters of all levels, with a beginner's section including instructions on stitching, general advice, and even an FAQ! As well as plenty of inspiration to uplift your décor this year, give your winter wardrobe a boost with beautiful accessories, including my personal favourite, the Patchwork Scarf. *Modern Crochet Style* is packed full of patterns to kick-start 2022 and get you reaching for the hooks, ready to take on the year ahead!

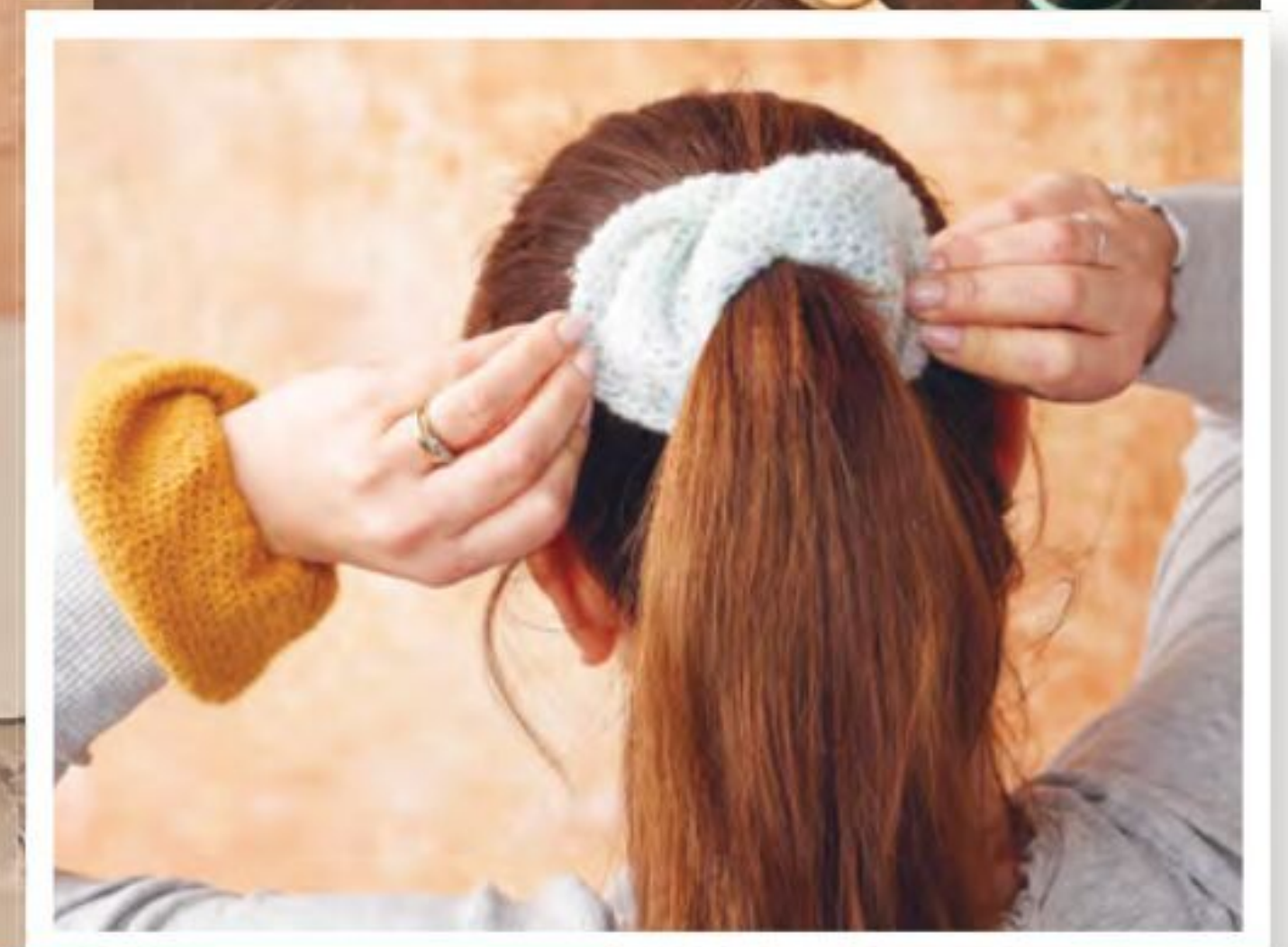
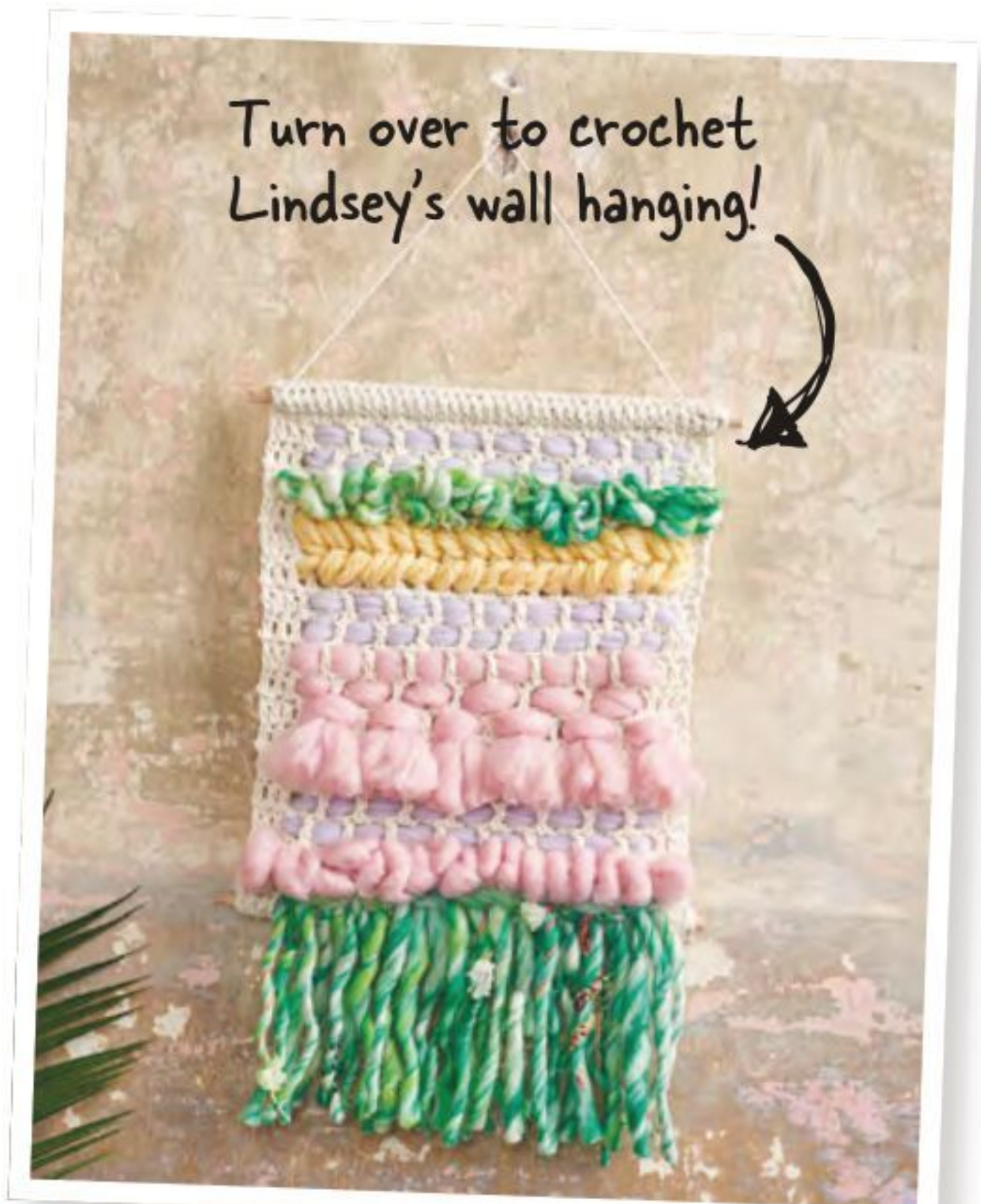



WOVEN WONDERS WALL HANGING

Do you have leftover yarn that you don't know what to do with?
Have a go at recreating this vibrant design
and impress friends and family!

 Aran  5mm

★★ Try something new

Yarn used

Rico Creative Cotton Aran
1 ball in Natural 60 (A)
Selection of scrap yarns. Chunky and super chunky yarns (or thinner yarns with multiple strands held together) work best
Aran weight yarn in lilac (B)
Chunky yarn in green (C)
Chunky yarn in yellow (D)
Super chunky yarn in pink (E)

About the yarn

Aran; 85m per 50g ball; 100% cotton

Hook used

5mm

Other supplies

tapestry needle
2 x 25cm lengths of 5mm wooden dowel

Sizing

30cm high x 22cm wide

.....
The cotton yarn for this weave provides strength and stability.

Start crocheting...

Crochet base (Fig. 1)

With A, chain 42, leaving a 30cm beg tail.

Row 1: Starting in 4th ch from hook, tr across. Turn. 40 sts

Row 2: 3 ch, tr across. Turn.

Row 3: 3 ch, working in FLO, 1 tr, [1 tr, 1 ch, miss 1 st] 17 times, 4 tr. Turn.

Row 4: 3 ch, 1 tr, [1 tr, 1 ch, miss 1 st] 17 times, 4 tr. Turn.

Rows 5-19: Rep Row 4.

Row 20: 3 ch, working in BLO of sts and chs, tr across. Turn.

Row 21: 3 ch, tr across.

Cut yarn leaving a long 30cm tail, and fasten off with a sl st.

Rya Knots

Fold a length of yarn in half and place the midpoint on top of one ch-sp, wrap the ends of the yarn around the two tr and into the ch-sps either side, to the back of the work. (Fig. 2) Finally, pull the two ends to the front through the middle ch-sp, pull gently to tighten. (Fig. 3)

Loops

Holding a length of yarn firmly behind the work, insert a crochet hook into the first ch-sp, yrh, then pull up a loop to the front of the work, without pulling the yarn tail all the way through to the front. Remove your crochet hook, leaving your loop in place. If your loop does not stay put, double or triple up your yarn to create a thicker loop. Rep in the next ch-sp along, or in every 2nd/3rd ch-sp etc, depending on the thickness of your yarn. (Fig. 4)



Fig. 1



Fig. 2

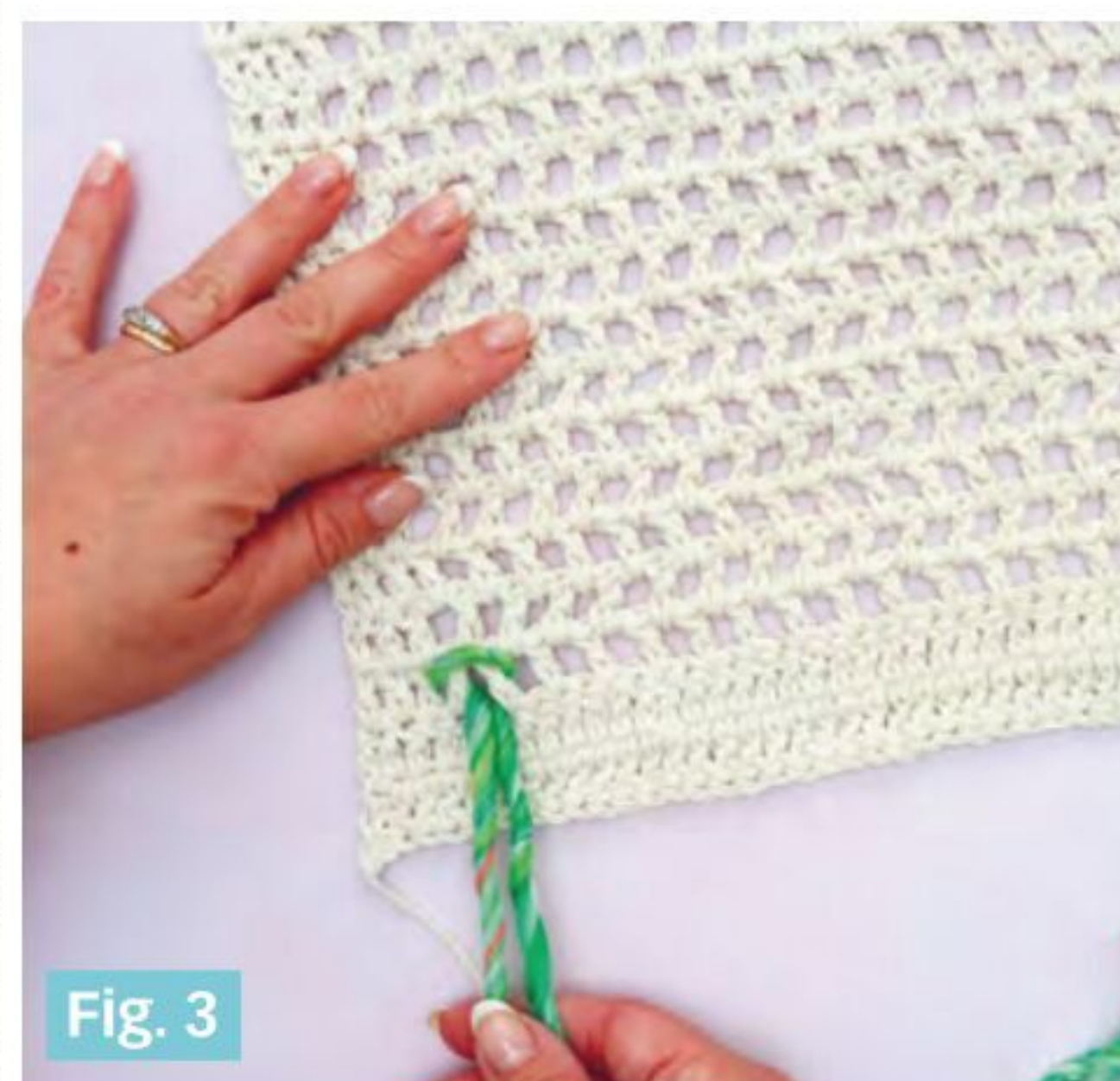

Fig. 3



Fig. 4



Fig. 5



Fig. 6



Fig. 7

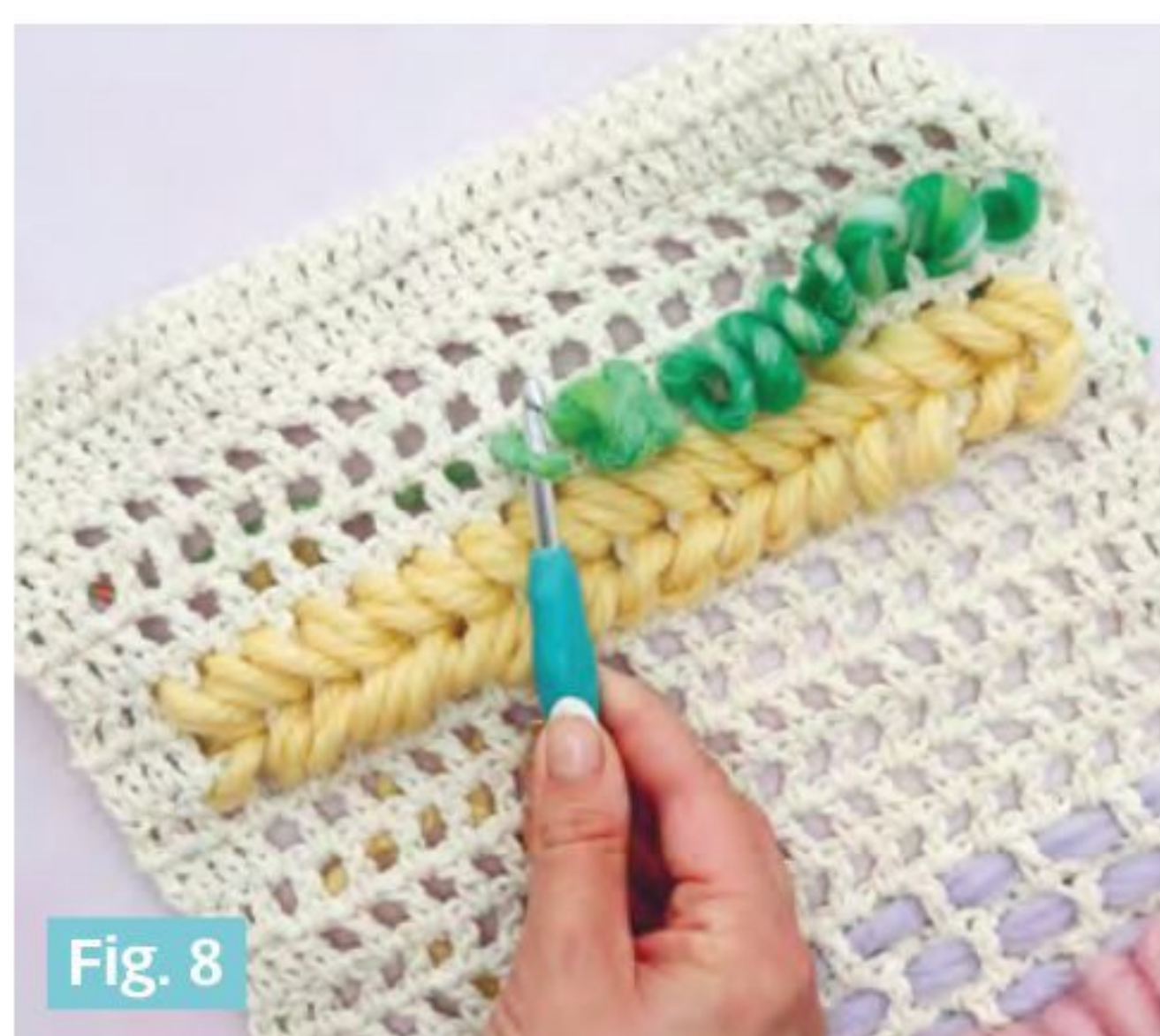

Fig. 8



Fig. 9

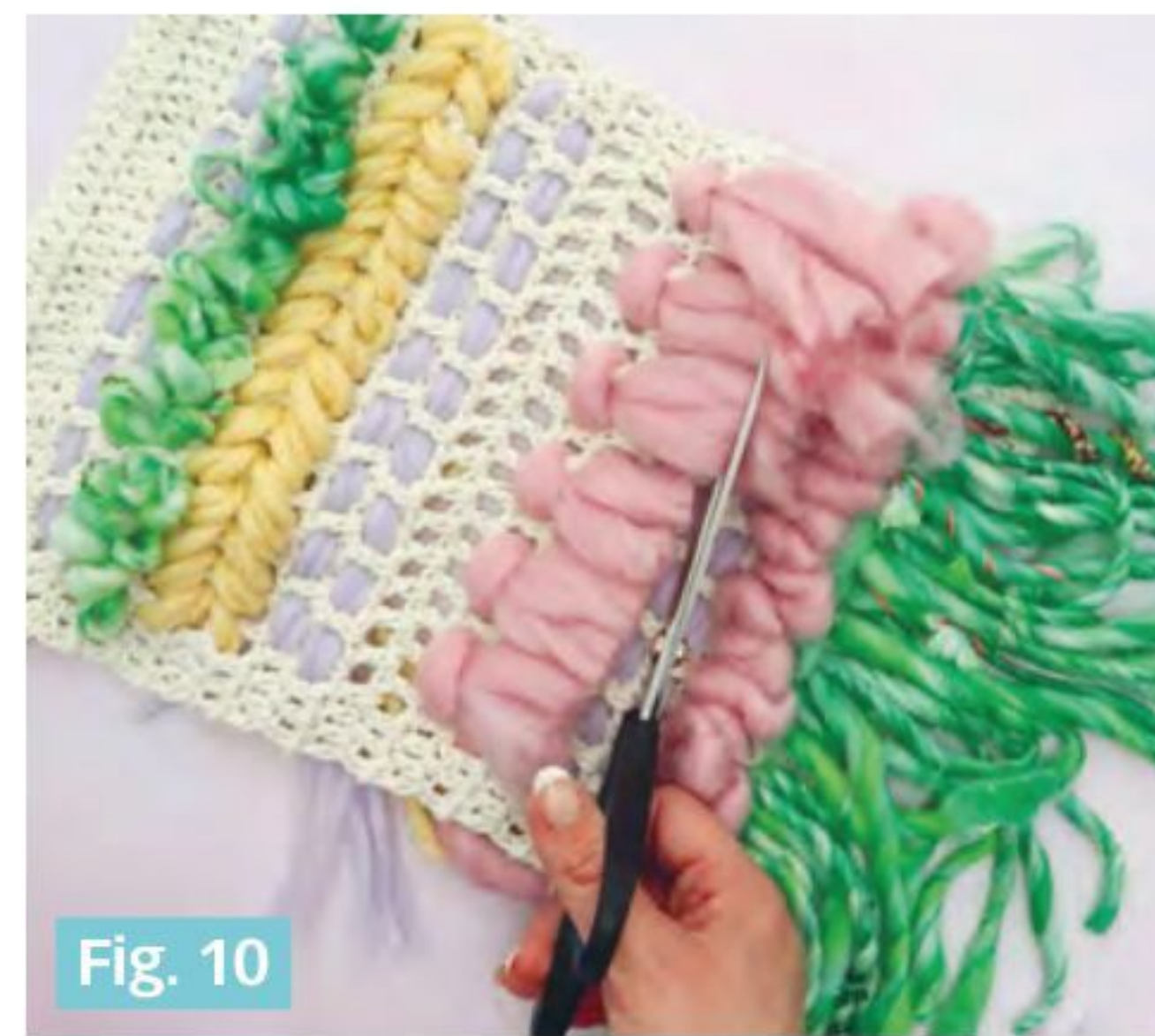

Fig. 10



Fig. 11

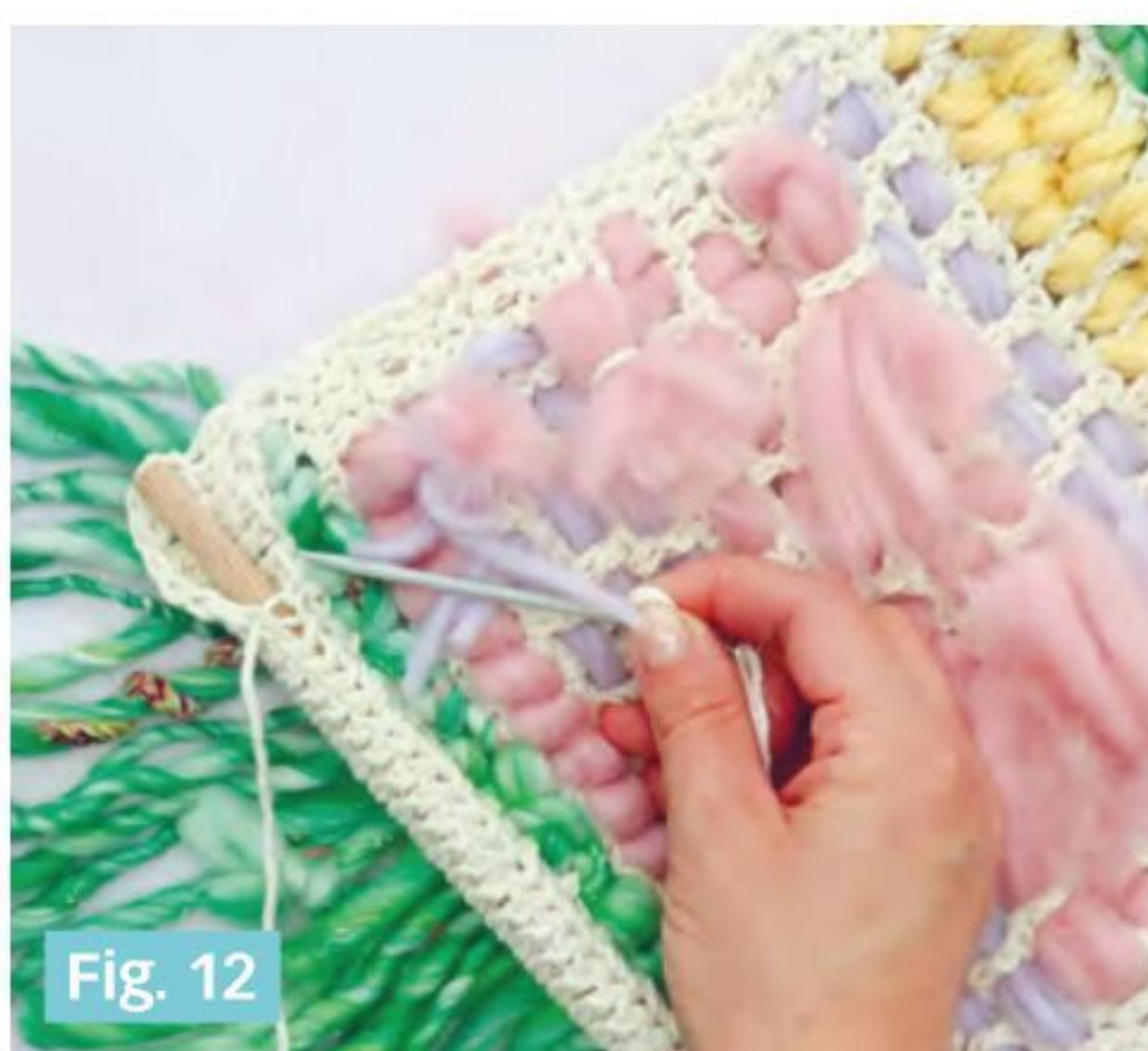

Fig. 12

Tabby Weave

(Fig. 5) Cut a length of yarn 2-3 times as wide as your crochet weave, then thread your yarn onto a large yarn needle. Starting from the back of the work, weave the yarn in and out of the ch-sps. If when you reach the end of the row you are on top of the work, come down on the other side of the nearest tr.

Soumak

(Fig. 6) A soumak is made by weaving diagonally from the first row into the second row below, then diagonally in the opposite direction from the second to third row. Choose 3 rows to work across and start top left. Bring your yarn to the front of the work in Row 1, then down to the back of the work in Row 2, choosing a ch-sp that

is not directly below, but on a diagonal. Rep until the end of the rows 1 and 2.

(Fig. 7) To make the second line, start on the far right of Row 2, and bring your yarn to the front of the work, then down to the back of the work through a ch-sp in Row 3. Work diagonally along rows 2-3 in the opposite direction to rows 1-2.

Weave pattern

Using your crochet as a base with the unworked loops of rows 3 and 20 on the WS of the work, weave as follows:

Row 3: With C, cut 17 x 35cm lengths and make a rya knot in every ch-sp. Trim knot ends to 12cm.

Row 4: With E, create a loop in each ch-sp.

Rows 5-7: With B, cut 3 x 2m lengths and hold triple, tabby weave.

Row 8: With E, tabby weave.

Row 9: With E, cut 11 x 15cm lengths. Place 6 rya knots evenly across the row. Trim knots ends to 3cm.

Rows 10-11: With E, tabby weave.

Rows 12-13: With B, cut 3 x 2m lengths and hold triple, tabby weave.

Rows 14-16: With D, cut 2 x 1m lengths, create a soumak over these 3 rows.

Row 17: With C, cut 2 x 1m lengths and hold double, create a loop in every ch-sp.

Rows 18-19: With B held triple, tabby weave.

Making up

Step 1: Once your weave is complete, secure any ends on the back of your work by tucking them in or tying off and cutting. Leave the two long crochet tail ends.

Step 2: (Figs. 11 & 12) Place your weave wrong-side up and lay the two wooden dowels on top of crochet rows 1-2 and 20-21. Using the long yarn tail, whip stitch through each st on Row 1 to the unworked loops from Row 3, encasing the dowel inside these two rows.

Step 3: Rep Step 2 for Row 21 and the unworked loops from Row 20. Secure ends by weaving in and trimming any excess.

Step 4: Finally, tie a 30cm piece of yarn to either end of the top dowel to hang your weave from. 🧶

find your next project with over
100 crochet yarn packs in
stock!



SHOP NOW AT
WOOLFULL.COM

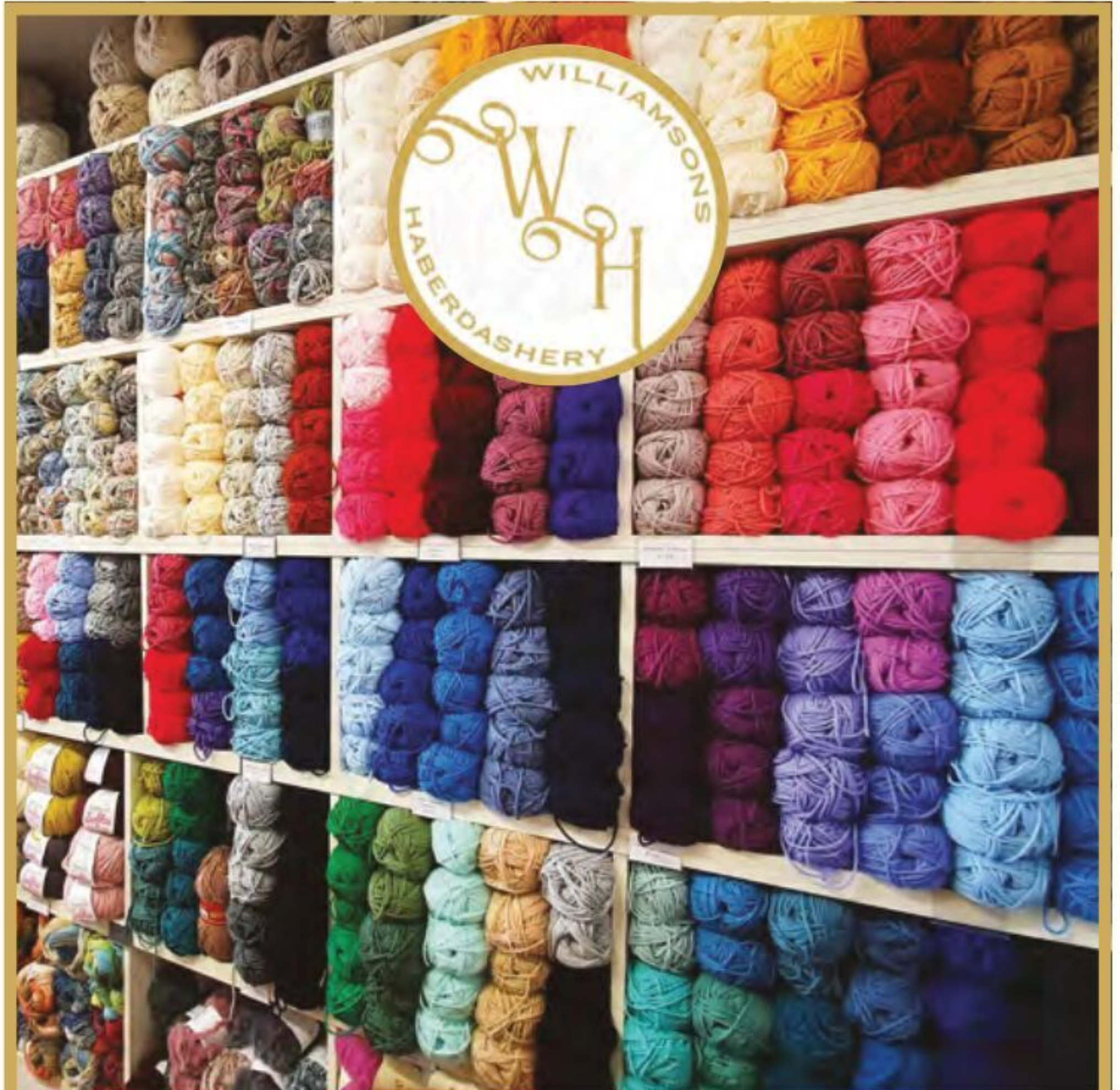

A Southampton based shop filled with beautiful yarns,
fabrics (including Liberty and Tilda)
and all of your other haberdashery needs!
Stocking King Cole, Stylecraft, Sirdar and Woolcraft/Jarol.

www.williamsonshaberdashery.co.uk

45 Victoria Road, Woolston, Southampton, SO19 9DY, UK

Williamsons Haberdashery **@williamsonshaberdashery**

THE
BARN

The Home of Haberdashery and Needlework

Workshops Fabric Yarn Wool And so much more...



Welcome to The Barn, set in the heart of Cornwall. We offer a space for all
handicrafts to include sewing classes, knitting, crochet, fused/stained glass and felting.

We sell fabric and yarn alongside artisanal handmade Cornish goods.

Find us at: St. Ingungers Farm,
Lanivet, Bodmin PL30 5HS

0780724321 | jv-thebarn@outlook.com
www.thebarncornwall.co.uk



Indie dyer of luxury wool
and plant fibre yarns.
Dyed in bright and vibrant
colours. Regular stock
updates, yarn club
subscriptions and seasonal
yarn boxes.

Dyed by myself in my dye
studio located in
North East Scotland.

www.rainbowfusions.com
rainbowfusionsuk@hotmail.com

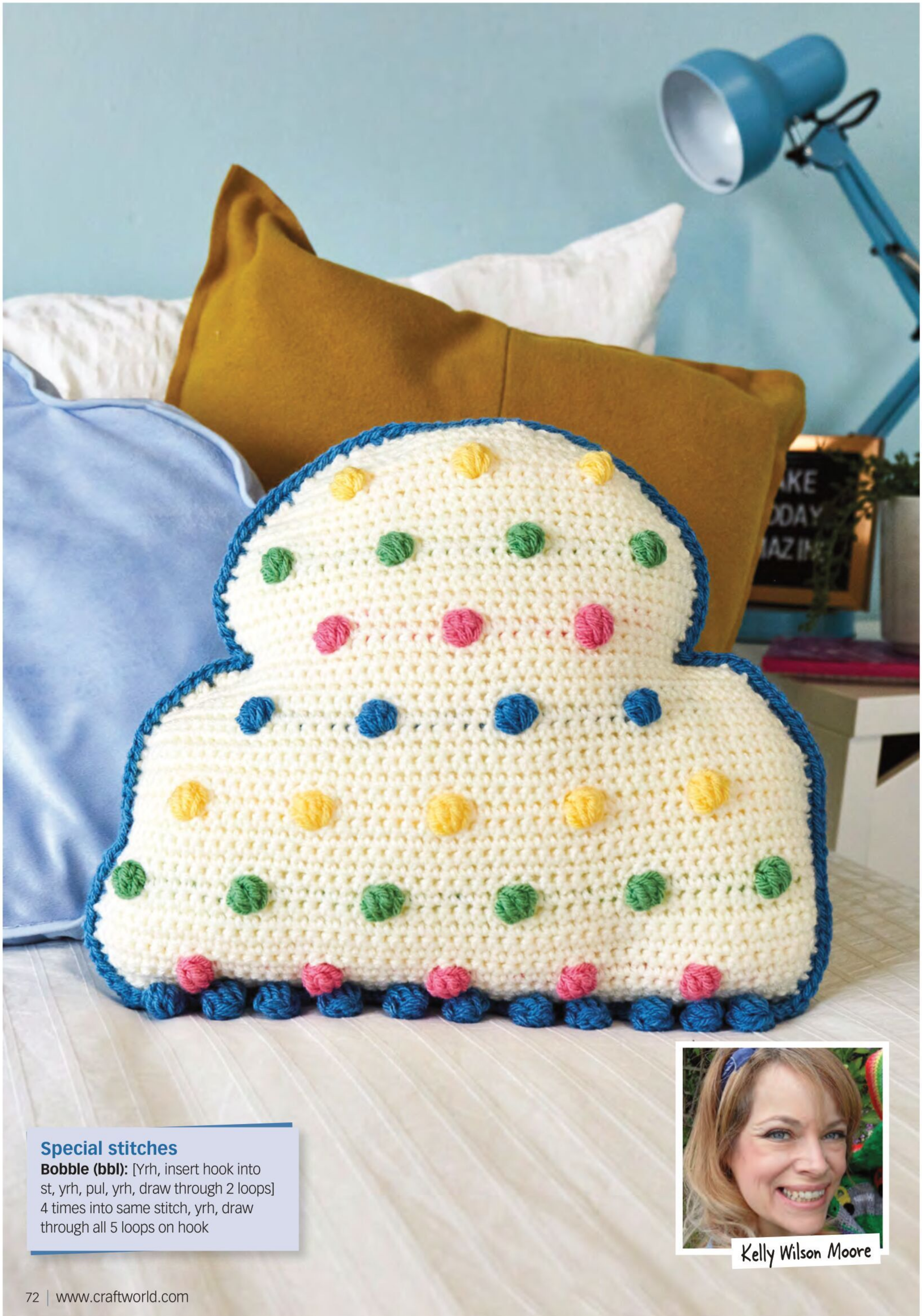

Special stitches

Bobble (bb): [Yrh, insert hook into st, yrh, pul, yrh, draw through 2 loops] 4 times into same stitch, yrh, draw through all 5 loops on hook



Kelly Wilson Moore

Bobble Cloud CUSHION

This colourful cloud cushion incorporates bobbles that look like raindrops

 **Chunky**  **6mm**

 **Beginner friendly**

Yarn used

Paintbox Yarns Simply Chunky
2 balls in Champagne White 302 (MC)
1 ball each in Bubblegum Pink 350 (CC1),
Spearmint Green 325 (CC2), Daffodil Yellow
321 (CC3) & Dolphin Blue 336 (CC4)
Available from www.lovecrafts.com

About the yarn

Chunky; 136m per 100g ball; 100% acrylic

Tension

13 sts x 14 rows = 10cm measured
over pattern

Hook used

6mm

Other supplies

toy stuffing

Sizing

32cm high x 37cm wide

To ensure your bobble stitches show on the RS of the work, push through with your crochet hook.

Beg 1 ch does not count as a st.

The cushion is made in two pieces which are then crocheted tog to join and stuffed part way through.

When making the bobble stitches, carry the unused yarn on the WS of work.

Start crocheting...

Front

With MC, chain 45.

Row 1 (RS): Starting in 2nd ch from hook, 43 dc, 2 dc in last ch. Turn. 45 sts

Row 2: 1 ch, 44 dc, 2 dc in last st. Turn. 46 sts

Row 3: 1 ch, 45 dc, 2 dc in last st. Turn. 47 sts

Row 4: 1 ch, 46 dc, 2 dc in last st. Turn. 48 sts

Row 5: 1 ch, 8 dc, *[1 bbl in CC1, 7 dc in MC] 5 times, 1 dc in same st as last st. Turn. 49 sts

Row 6: 1 ch, 48 dc, 2 dc in last st. Turn. 50 sts

Rows 7-10: 1 ch, dc across. Turn.

Row 11: 1 ch, 5 dc, [1 bbl in CC2, 7 dc in MC] 5 times, 1 bbl in CC2, 4 dc in MC. Turn.

Rows 12-16: 1 ch, dc across. Turn.

Row 17: 1 ch, 9 dc, [1 bbl in CC3, 7 dc in MC] 5 times, 1 dc. Turn.

Rows 18-19: 1 ch, dc across. Turn.

Row 20: 1 ch, 48 dc, 1 dc2tog. Turn. 49 sts

Row 21: 1 ch, 47 dc, 1 dc2tog. Turn. 48 sts

Row 22: 1 ch, 46 dc, 1 dc2tog. Turn. 47 sts

Row 23: 1 ch, 11 dc, [1 bbl in CC4, 7 dc in MC] 4 times, 2 dc, 1 dc2tog. Turn. 46 sts

Row 24: 1 ch, 44 dc, 1 dc2tog. Turn. 45 sts

Row 25: 1 ch, 43 dc, 1 dc2tog. Turn. 44 sts

Row 26: 1 ch, 41 dc, 1 dc3tog. Turn. 42 sts

Row 27: 1 ch, 39 dc, 1 dc3tog. Turn. 40 sts

Row 28: 1 ch, 35 dc, 2 dc in next st, leave rem 4 sts unworked. Turn. 37 sts

Row 29: 1 ch, 2 dc in first st, 7 dc, [1 bbl in CC1, 7 dc in MC] 3 times, 2 dc in next st, leave rem 4 sts unworked. Turn. 35 sts

Row 30: 1 ch, 2 dc in first st, 34 dc. Turn. 36 sts

Rows 31-34: 1 ch, dc across. Turn.

Row 35: 1 ch, 5 dc, [1 bbl in CC2, 7 dc in MC] 3 times, 1 bbl in CC2, change to MC, 4 dc, 1 dc2tog. Turn. 35 sts

Row 36: 1 ch, 33 dc, 1 dc2tog. Turn. 34 sts

Row 37: 1 ch, 32 dc, 1 dc2tog. Turn. 33 sts

Row 38: 1 ch, 31 dc, 1 dc2tog. Turn. 32 sts

Row 39: 1 ch, 30 dc, 1 dc2tog. Turn. 31 sts

Row 40: 1 ch, 29 dc, 1 dc2tog. Turn. 30 sts

Row 41: 1 ch, 5 dc, [1 bbl in CC3, 7 dc in MC] twice, 1 bbl in CC3, change to MC, 5 dc, 1 dc3tog. Turn. 28 sts

Row 42: 1 ch, 25 dc, 1 dc3tog. Turn. 26 sts

Row 43: 1 ch, 23 dc, 1 dc3tog. Turn. 24 sts

Row 44: 1 ch, 21 dc, 1 dc3tog. Turn. 22 sts

Row 45: 1 ch, 1 dc3tog, 16 dc, 1 dc3tog. Turn. 18 sts

Row 46: 1 ch, 1 dc3tog, 12 dc, 1 dc3tog. Turn. 14 sts

Row 47: 1 ch, 1 dc3tog, 8 dc, 1 dc3tog. Turn. 10 sts

Back

With MC, work as for Front omitting all bbls: replace every 1 bbl with 1 dc in MC.

Joining

Hold both pieces tog with the RS of Back Piece facing the WS of Front Piece. With RS of Front Piece facing, join CC4 to the bottom left-hand corner working through both pieces. Dc along bottom edge and evenly around all rem edges, stuffing as you go. Join with sl st to beg dc. Do not fasten off.

Bottom edge

Row 1: Cont with CC4 and working along bottom edge, *5 ch, 1 bbl in 3rd ch from hook, 3 ch, sl st in same ch as bbl, 2 ch, miss 3 sts, sl st in next st; rep from * 10 times more. Fasten off. 11 bbl

Weave in ends. 





Isabel Vidaurre

DULCE PONCHO

Face the winter head on with this stunning poncho, made from a mix of yarns

 Sport & lace  4.5mm

★ ★ Try something new

Yarn used

Rowan Baby Cashsoft Merino
12 (14, 15) balls in Vintage Pink 105

Rowan Kidsilk Haze
6 (7, 8) balls in Grace 580

Visit www.knitrowan.com to find your local stockist

About the yarn

Sport; 130m per 50g ball; 57% Merino wool, 33% acrylic, 10% cashmere
Lace; 210m per 25g ball; 70% mohair, 20% silk

Tension

14 sts x 9 rows = 10cm measured over tr, with 1 strand of Baby Cashsoft Merino and one strand of Kidsilk Haze held together

Hook used

4.5mm

Other supplies

16 removable stitch markers

Sizing

S (M, L) designed to fit 81-86 (101.5-106.5, 122-127) cm chest circumference

Finished size:

A: 120 (135, 140) cm (measured flat)

B: 63 (67, 69) cm

C: 23.5 (26.5, 26.5) cm

To avoid the gaps that appear when joining in the round, join with sl st in the top of the

first tr, instead of in top of 3rd chain.

Crochet carefully and check for mistakes every so often. Undoing long crochet sections is very difficult when working with mohair.

This pattern is worked flat for the neck shaping then joined to work in the round.

Beg 3 ch counts as first tr.

Work with 1 s strand of Kidsilk Haze held together throughout.

Start crocheting...

Neck shaping

Chain 52 (58, 58).

Row 1 (WS): Starting in 4th ch from hook, 49 (55, 55) tr. Turn. 50 (56, 56) sts

Row 2 (RS): 3 ch, 1 tr in first st, 2 tr, 2 tr in next st, [2 (3, 3) tr, 2 tr in next st, 2/2 C, 2 tr in next st] 5 times, 2 (3, 3) tr, 2 tr in next st, 2 tr, 2 tr in last st. Turn. 64 (70, 70) sts

Row 3: 3 ch, 1 tr in first st, 9 (10, 10) tr [2/2

Special stitches

Raised double treble Front (RdtrF):

Work the dtr around the post of the st inserting hook from front to back around to front again

Raised triple treble Front (RtrtrF):

Work the ttr around the post of the st inserting hook from front to back around to front again

Raised quadruple treble Front (RquadtrF):

Work the quadruple tr around the post of the st inserting hook from front to back to around front again

2/2 cable (2/2 C):

RS: Miss 2 sts, 2 RdtrF, starting in the first of the 2 missed sts, 2 RdtrF

WS: 4 RtrB when working flat, 4 RtrF when working in the round

3/3 cable (3/3 C):

RS: Miss 3 sts, 3 RtrtrF, starting in the first of the 3 missed sts, 3 RtrtrF

WS: 6 RtrF

4/4 cable (4/4 C):

RS: Miss 4 sts, 4 RquadtrF, starting in the first of the 4 missed sts, 4 RquadtrF

WS: 8 RtrF

Schematic

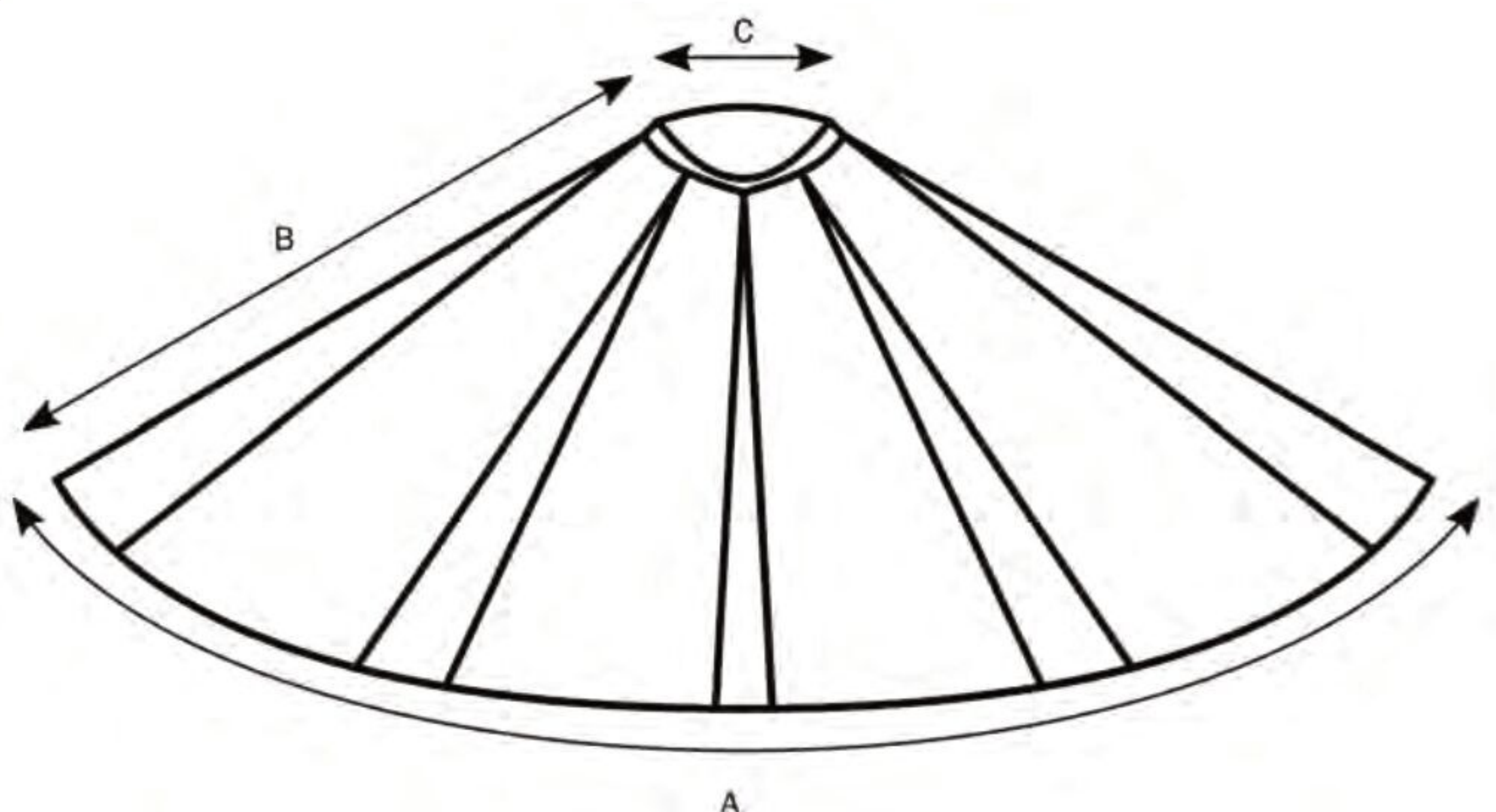

Garment



C, 6 (7, 7) tr] 5 times, 3 tr, 2 tr in last st.
Turn. 66 (72, 72) sts

Row 4: 3 ch, 1 tr in first st, [2/2 C, 2 tr in next st, 4 (5, 5) tr, 2 tr in next st] 6 times, 2/2 C, 2 tr in next st, 16 (18, 18) ch. Do not turn.

Join to work in the rnd, being careful not to twist. 96 (104, 104) sts

Yoke

From now on, you will work in the round. Join each rnd with a sl st in top of beg 3 ch, do not turn.

Treat even rounds as RS and odd rounds as WS as you work the cables.

On Rnd 1, place markers in the tr before each 2/2 C and the tr after each 2/2 C. Move markers up as you work, keeping them in the sts closest to the 2/2 C.

Rnd 1: 3 ch, 1 tr, [pm, 2/2 C, pm, 8 (9, 9) tr] 7 times, pm in last st made, 5 tr, pm in last st made, 5 (6, 6) tr, join.

Rnd 2: 3 ch, [tr around to marked st, 2 tr in marked st, 2/2 C, 2 tr in marked st] 8

times, tr to end, join. 16 sts inc'd

Rnd 3: 3 ch, [tr around to cable, 2/2 C] 8 times, tr to end, join.

Rep rnds 2-3 five (6, 7) times more.

192 (216, 232) sts

Body

Next Rnd: 3 ch, [tr around to cable, miss 2 sts, 2 RtrtrF around next st, 1 RtrtrF, starting in the first of the 2 missed sts, 1 RtrtrF, 2 RtrtrF around next st] 8 times, tr to end, join. 208 (232, 248) sts

Rnd 1 & all odd rnds through Rnd 7: 3 ch, [tr around to cable, 3/3 C] 8 times, tr to end, join.

Rnd 2: 3 ch, [tr around to cable, 3/3 C] 8 times, tr to end, join.

Rnd 4: 3 ch, [tr around to marked st, 2 tr in marked st, 3/3 C, 2 tr in marked st] 8 times, tr to end, join. 16 sts inc'd

Rnd 6: As Rnd 2.

Rnds 8-19: Rep rnds 4-7 three times more. 272 (296, 312) sts

Rnd 20: 3 ch, [tr around to cable, miss 3 sts, 1 RquadtrF, 2 RquadtrF around next st, 1 RquadtrF, starting in first of the 3 missed sts, 1 RquadtrF, 2 RquadtrF around next st, 1 RquadtrF] 8 times, tr to end, join. 288 (312, 328) sts

Rnd 21 & all odd rnds through Rnd 27: 3 ch, [tr around to cable, 4/4 C] 8 times, tr to end, join.

Rnd 22: 3 ch, [tr around to cable, 4/4 C] 8 times, tr to end, join.

Rnd 24: 3 ch, [tr around to marked st, 2 tr in marked st, 4/4 C, 2 tr in marked st] 8 times, tr to end, join. 16 sts inc'd

Rnd 26: As Rnd 2.

Rnds 28-35: Rep rnds 24-27 twice more. 336 (360, 376) sts, 34 (37, 39) sts between cables

SIZES M & L ONLY:

Rep rnds 24-25 once more. - (376, 392) sts, - (39, 41) sts between cables

ALL SIZES:

Work Picot Rnd as follows: 3 ch, sl st in first st, 1 dc, *[1 dc, 3 ch, 1 sl st] in next st, 1 dc; rep from * to end, join.

Neck Rib

Rnd 1: Work 80 (88, 88) tr evenly around the neckline.



Rnds 2-3: 3 ch (does not count as a st), *1 RtrF, 1 RtrB; rep from * to end, join. Fasten off.

Weave in ends and block to dimensions given in schematic. 

POPCORN SCARF

We're so excited to 'pop' this super-cosy scarf in this month's issue, and can't wait to make one ourselves!

Designed by *Michelle Wray*

 Mega-chunky  15mm

★★ Try something new

Yarn used

King Cole Rosarium
7 balls in Rose Petal 4704
Visit www.kingcole.com to find your local stockist

About the yarn

Mega-chunky; 40m per 100g ball;
100% Merino wool

Tension

5.5 sts x 4 rows = 10cm measured over pattern

Hook used

15mm

Sizing

18.5cm wide x 155cm long

There will be 4 popcorns on every other row.

Beg 1 ch does not count as a stitch.

Start crocheting...

Chain 11.

Row 1: Starting in 2nd ch from hook, working in back bumps, dc across. Turn. 10 sts

Row 2: 1 ch, 1 dc, *1 PC, 1 dc; rep from * to last st, 1 dc. Turn. 6 dc, 4 PC

Row 3: 1 ch, dc across. Turn. 10 sts

Rows 4-67: Rep rows 2-3 thirty two times more.

Fasten off. Weave in ends. 

Special stitches

Popcorn (PC): 4 tr in next st, remove hook from loop, insert hook

from back to front of first tr made, replace loop on hook, yrh, draw tightly through loop and st on hook



Looking for Christmas ideas?

Explore our magical selections
boxes and kits like this
Honeycomb Blanket pack
in wool or acrylic



For £5 off our boxes or kits use code: **MerryKitmas**



Ammonite Yarns

www.ammoniteyarns.co.uk

Visit our shop at 7 Llantrisant Road, Pontyclun CF72 9DP



Fabrics Plus Limited

Fabrics Plus Limited

The home of beautiful Fabric, Yarn and more

19 Badminton Road
Downend
BS16 6BB

Tel No:- 0117 329 3857
www.fabrics-plus.co.uk

Fabrics-Plus Limited fabricspluslimited

We stock a large range of yarn from Stylecraft, King Cole and West Yorkshire Spinners, lots of beautiful craft fabric from Moda, Makower and more, a large selection of dress making fabrics plus, we now have an Upholstery Department too. Also in store is a large selection of haberdashery items.

GET 10% OFF YOUR FIRST ORDER WITH CODE CN10.

We look forward to seeing you soon.



Free UK Delivery on orders over £25
Click and Collect available



Yarn | Fabric | Accessories



10% OFF
first order use code
CNM77

Shop online at
www.woolandcrafts.co.uk

Follow us on

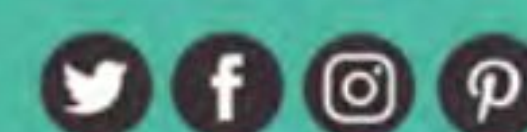

Unit 4a The Courtyard
9-13 Coventry Road
Burbage, Hinckley
LE10 2HL

01455 238768

The Yarn Shack

Get 10% off
your first
order
with promo -
code **FIRST10**

Welcome to The Yarn Shack!

At The Yarn Shack, we're crazy about yarn and we understand that crafting, isn't just a hobby, it's a way of life. So whether you would like to order some yarn, show us your projects or talk to us about a pattern you're stuck on, we're here and we would love to hear from you!

Visit our online yarn shop...
www.theyarnshackworcs.co.uk
07943072259

@theyarnshack The Yarn Shack Worcestershire

STANDARD ABBREVIATIONS

Get your head around these abbreviations that you'll find regularly in *Crochet Now* patterns

alt	alternate
beg	beginning
BLO	work in back loops only
CC	contrasting colour
ch	chain
ch-sp	chain space
cont	continue
dc	double crochet
dc2tog	work two double crochet stitches together
dec	decrease
dtr	double treble crochet
fdc	foundation double crochet
FLO	work in front loops only
foll	following
htr	half treble crochet
htr2tog	work two half treble crochet stitches together
inc	increase
LH	left hand
MC	main colour
patt	pattern
pm	place marker
prev	previous
pul	pull up a loop
rem	remaining
rep	repeat
RH	right hand
rm	remove marker
rnd	round
RS	right side
RtrF	raised treble front: Yrh, insert around post of indicated st from front to back around to front again, yrh, pul, [yrh, draw through two loops] twice
RtrB	raised treble back: Yrh, insert around post of indicated st from back to front around to back again, yrh, pul, [yrh, draw through two loops] twice
sl st	slip stitch
sp	space

st(s)	stitch(es)
tbl	through the back loop
tr	treble crochet
ttr	triple treble
tr2tog	work two treble crochet stitches together
WS	wrong side
yrh	yarn round hook

US to UK crochet terms

If you come across a 'sc' instruction, it's likely to be written in US crochet terms. *Crochet Now* is written entirely in UK terms, but here's a guide on how to translate them.

US		UK	
Single crochet	sc	Double crochet	dc
Half double	hdc	Half treble	htr
Double	dc	Treble	tr
Treble	tr	Double treble	dtr
Double treble	dtr	Triple treble	ttr

Crochet hook conversions

UK	In mm	US
14	2mm	-
13	2.25mm	B/1
12	2.5mm	-
-	2.75mm	C/2
11	3mm	-
10	3.25mm	D/3
9	3.5mm	E/4
-	3.75mm	F/5
8	4mm	G/6
7	4.5mm	7
6	5mm	H/8
5	5.5mm	I/9
4	6mm	J/10
3	6.5mm	K/10.5
2	7mm	-
0	8mm	L/11
00	9mm	M/13
000	10mm	N/15

Master beginner crochet techniques by following our step-by-step guides - only available at www.craftworld.com

Editorial
Editor Hannah Williams
Senior Editor Jenny Conduit
Technical Editors Amy Curtin, Lindsey Stephens, Sharon Carter
Chief Sub-Editor Kayleigh Hooton
Sub-Editor Victoria Smith
Content Executive Jayne Edwards
Lead Designer Mel Greenhalgh
Photographers Tym Leckey, Renata Stonyte
Covermount & Packaging Designer Becca Hollins

Contributors
 Kerry Lord, Sarah-Jayne Fragola, Esther Dijkstra, Janine Myskae, Angela Hatton, Matt Farci, Lindsey Newns, Victoria Barrett, Isabel Vidaurre, Jane Howarth, Michelle Wray, Sue Pearson, Jane Howarth, Zoë Potrac, Becca Parker, Andreia Ferreira, Victoria Kairis, Inas Fadil Basymeleh, Kelly Wilson Moore

Advertising
Account Manager Chris Cooke
 chris.cooke@practicalpublishing.co.uk

Publishing
Head of Content Kate Heppell
Group Buying & Licensing Controller Lucy Pedder
Group Business Development Manager Chris Cooke
Head of Product Carol Jones
Head of Publishing Ruth Walker
Strategy & Insights Director Dave Cusick
Managing Director Danny Bowler
Group Managing Director Robin Wilkinson

Subscription Enquiries
 Tel: 0161 327 0441
 subscriptions@practicalpublishing.co.uk

Other Enquiries
 customerservice@practicalpublishing.co.uk
 Tel: 0844 561 1202

Distribution
 Seymour Distribution Ltd
Craft Store Distribution
 stacey.oldman@practicalpublishing.co.uk



Contact
 Practical Publishing International Ltd,
 Suite G2 Vitality House, 217 Wellington Road South,
 Stockport SK2 6NG
 www.practicalpublishing.co.uk
 Tel: 0844 561 1202

Crochet Now is published by Practical Publishing International Ltd. All material © Practical Publishing International Ltd. The style and mark of *Crochet Now* is used under licence from Practical Publishing International Holdings Ltd. No material in whole or in part may be reproduced, stored or transmitted in any form whatsoever without the prior written consent of Practical Publishing International Ltd. The publisher welcomes contributions from readers. All such contributions and submissions to the magazine are sent to and accepted by the publisher on the basis of a non-exclusive transferable worldwide licence unless otherwise agreed in writing prior to first publication. Such submissions are also subject to being used, reproduced, modified, published, edited, translated, distributed and displayed in any media or medium, or any form, format or forum now known or hereafter developed, for any purpose, in perpetuity.

Crochet Now (ISSN 2047-4911).

Published by Practical Publishing International Ltd
 Stock images provided by Shutterstock, Inc.



Inside the next issue of **crochet** *now*

Mindful Makes



As we start to think about spring, take a moment to breathe slowly as you work through this beautiful collection of mindful crochet makes. Soothing blues with pops of coral and cool greens lead this collection of must-make accessories and blankets, loose and layering garments and the regular dose of cute but themed amigurumi toys



DON'T MISS

LUXURY HOOK & STITCH MARKER SET



PLUS

Exclusive Mental Health UK Mandala Supplement



3 cosy blankets



Comfortable clothing

Issue 78
ON SALE
3rd February



Tranquil toys



Happy décor

Contents and on-sale dates subject to change

FREE Crochet Society Coco Cushion CAL when you subscribe!
www.practicalsubs.com/7306



Angela Hatton



MAKE WITH THE Stylecraft EXPERT!

Hook up this colourful blanket that's perfect for keeping you warm this winter!

Someewhere over the rainbow

 **Chunky**  **6mm**

 **Beginner friendly**

Yarn used

Stylecraft Softie
4 balls in Indigo 2132 (E)
2 balls in Fern 2418 (D)
1 ball each in Raspberry 3110 (A),
Coral 2361 (B) & Zest 3985 (C)

Visit www.stylecraft-yarns.co.uk to find your local stockist

About the yarn

Chunky; 170m per 100g ball; 80% acrylic
20% wool

Tension

12 sts x 7 rnds = 10cm measured over tr

Hook used

6mm

Sizing

150cm diameter from point to point when pinned out

Sometimes our tension becomes looser as

we relax into a pattern we have become used to – this may cause some puckering the larger the blanket becomes, preventing a neat flat shape when finished. If you find this happening, you can either go down a hook size or try increasing every other rnd on the last few colours.

For a smaller blanket, you can try working fewer rnds per colour or try making the blanket in just 1 or 2 colours.

Start crocheting...

With B, chain 5. Join with sl st in 5th ch from hook to form a ring.

Rnd 1 (RS): 1 ch (does not count as a st), 14 dc into ring, join with sl st to beg dc. *14 sts*

Rnd 2: Beg cl in first st, [3 ch, miss 1 st, 1 cl] 6 times, 3 ch, miss 1 st, join with sl st to beg cl. *Fasten off. 7 cl*

Rnd 3: Join A with sl st in any 3ch-sp, 6 ch (counts as 1 tr, 3 ch), [1 tr into next 3ch-sp, 3 ch] 6 times, join with sl st in 3rd ch of beg 6 ch. *7 sts, 7 ch-sps*

Rnd 4: 3 ch (counts as first tr here and throughout), 2 tr in same st as join, [2 ch, 3 tr in next st] 6 times, 2 ch, join with sl st in top of beg 3 ch. *21 sts, 7 ch-sps*

Rnd 5: 3 ch, 3 tr in next (centre) st, 1 tr, 2

ch, miss 2ch-sp, [1 tr, 3 tr in next (centre) st, 1 tr, 2 ch, miss 2ch-sp] 6 times, join with sl st in top of beg 3 ch. *35 sts, 7 ch-sps*

Rnd 6: 3 ch, [tr across to centre st, 3 tr in centre st, tr across to next 2ch-sp, 2 ch, miss 2ch-sp] 7 times, join with sl st in top of beg 3 ch. *14 sts inc'd*

Rep Rnd 6 until there are a total of 8 rnds in A. Fasten off.

Join B with sl st in first st after any 2ch-sp, rep Rnd 6 eight times. Fasten off.

Join C with sl st in first st after any 2ch-sp, rep Rnd 6 eight times. Fasten off.

Join D with sl st in first st after any 2ch-sp, rep Rnd 6 eight times. Fasten off.

Join E with sl st in first st after any 2ch-sp, rep Rnd 6 eight times. Fasten off.

Finishing

Weave in ends. Pin out to shape. 

Special stitches

Beginning cluster (beg cl): 2 ch, [yrh, insert hook in first st, yrh, pul, yrh, draw through 2 loops] twice, yrh, draw through all 3 loops on hook

Cluster (cl): [Yrh, insert hook in indicated st, yrh, pul, yrh, draw through 2 loops] 3 times in same st, yrh, draw through all 4 loops on hook

YARN
AND
COLORS.



AMAZING.

CRAFT SUSTAINABLE WITH OUR NEW **AMAZING** DK YARN. MADE FROM 100% RECYCLED ACRYLIC.

AVAILABLE AT WWW.LOVECRAFTS.COM OR SCAN THE QR CODE.



AS SEEN IN
YARN
THE AFTER PARTY
NUMBER 154

FOLK TREES
BLANKET

By Esme Crick

Scheepjes[®]

INSPIRATION IN EVERY BALL OF YARN

Colour Crafter

RRP €3,15 | £2.25 | USD 3.50

 DK weight  4mm



*coming
soon*



Colour and craft go hand in hand, which is why we created our everyday essential, DK weight yarn, Colour Crafter! No matter how big or small the project, this yarn does it all. Made from 100% Premium Acrylic with Anti Pilling, Colour Crafter is a versatile DK weight yarn available in over 90 glorious shades. Being lightweight, hypoallergenic and easy care, this yarn is an excellent choice for a vast range of projects from blankets, homeware items and children's toys.

Scheepjes products are available worldwide. Locate your nearest local stockist or online store via our website:

www.scheepjes.com/en/shops

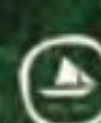
 www.scheepjes.com

 [instagram.com/scheepjes](https://www.instagram.com/scheepjes)

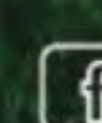
 [facebook.com/scheepjes](https://www.facebook.com/scheepjes)